



THE NATIONAL PIPE ARCHIVE

Registered Charity Number 1043065

Accession Number: LIVNP 1998.09.01 (part 2)

Description: Part 2 of Vol. 1 of Colin Tatman's unpublished notes and drawings of pipes and hair curlers (Vol. 4) recovered from sites in London and Kent, pages 72 to 179.

Comments: For each figure there is a caption which includes the date and site of recovery; the date of the pipe (or hair curler – Vol. 4) followed by a description. The figures are grouped by find spot and then illustrated in chronological order. This is the second part of Volume 1 which covers 2 groups of pipes recovered from Blackfriars to Dowgate (N. Bank), R. Thames: the first group dated c1690-1730 and the second group dated c1720-1780.

Key Words: Clay pipes; London; Blackfriars; Dowgate; River Thames; Thames foreshore; Queenhithe; Vintry Wharf; Southwark; Trig Lane Stairs.

Scanned: PDF 7 December 2016

Any images in this PDF must not be lent, copied to another party, sold or reproduced in any way without prior permission from the National Pipe Archive and the copyright owner, if applicable. Reproduction or publication in any medium is expressly forbidden without written authorisation and should include an acknowledgement worded 'Courtesy of the National Pipe Archive' and quoting the relevant accession number.

BLACKFRIARS to DOWGATE (N. BANK.)

R. THAMES.

1/1 - C. 1690 to 1730.

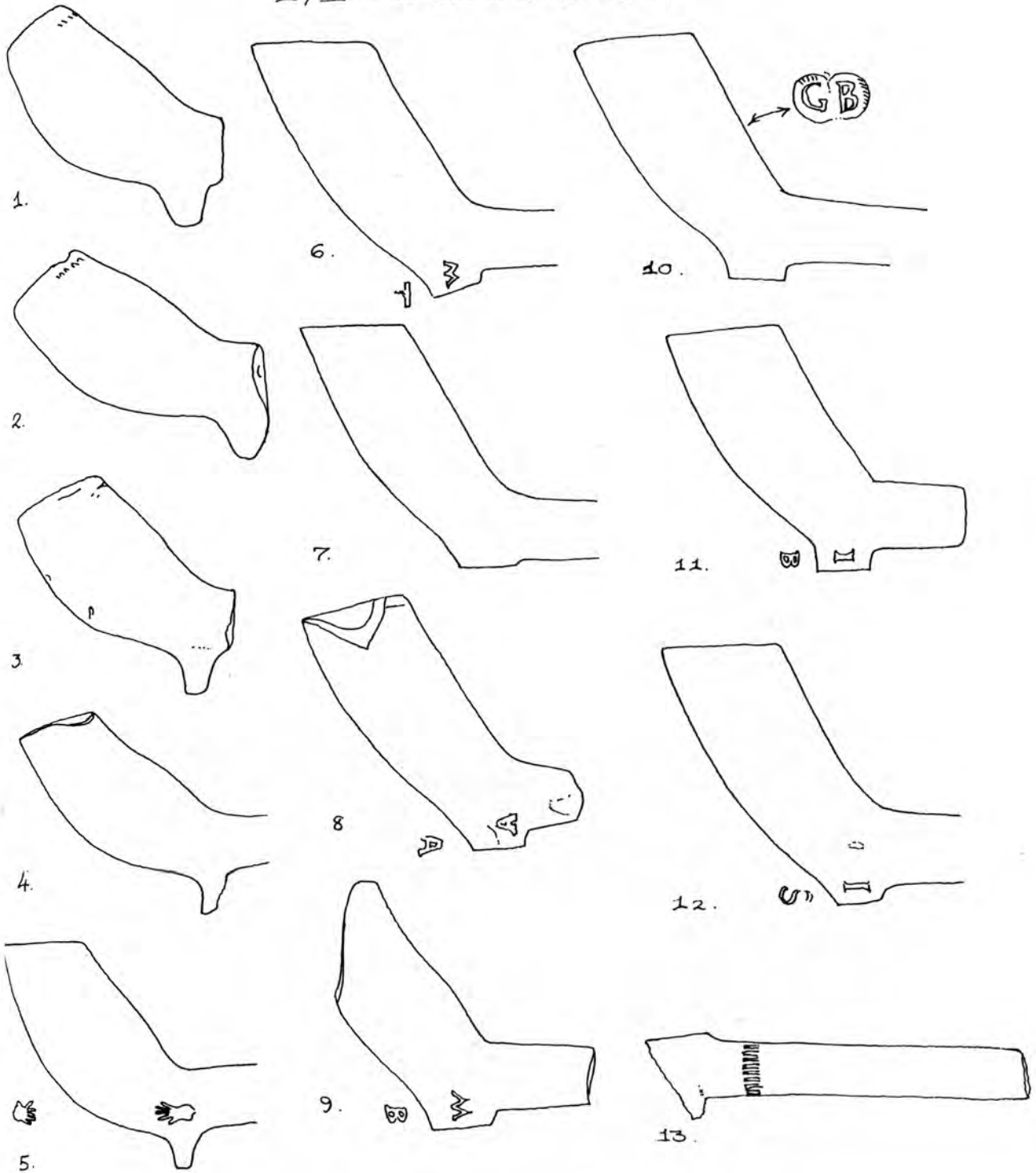

FIG. 1.



BLACKFRIARS to DOWGATE (N. BANK.)

R. THAMES.

1/1 - C.1690 to 1730.

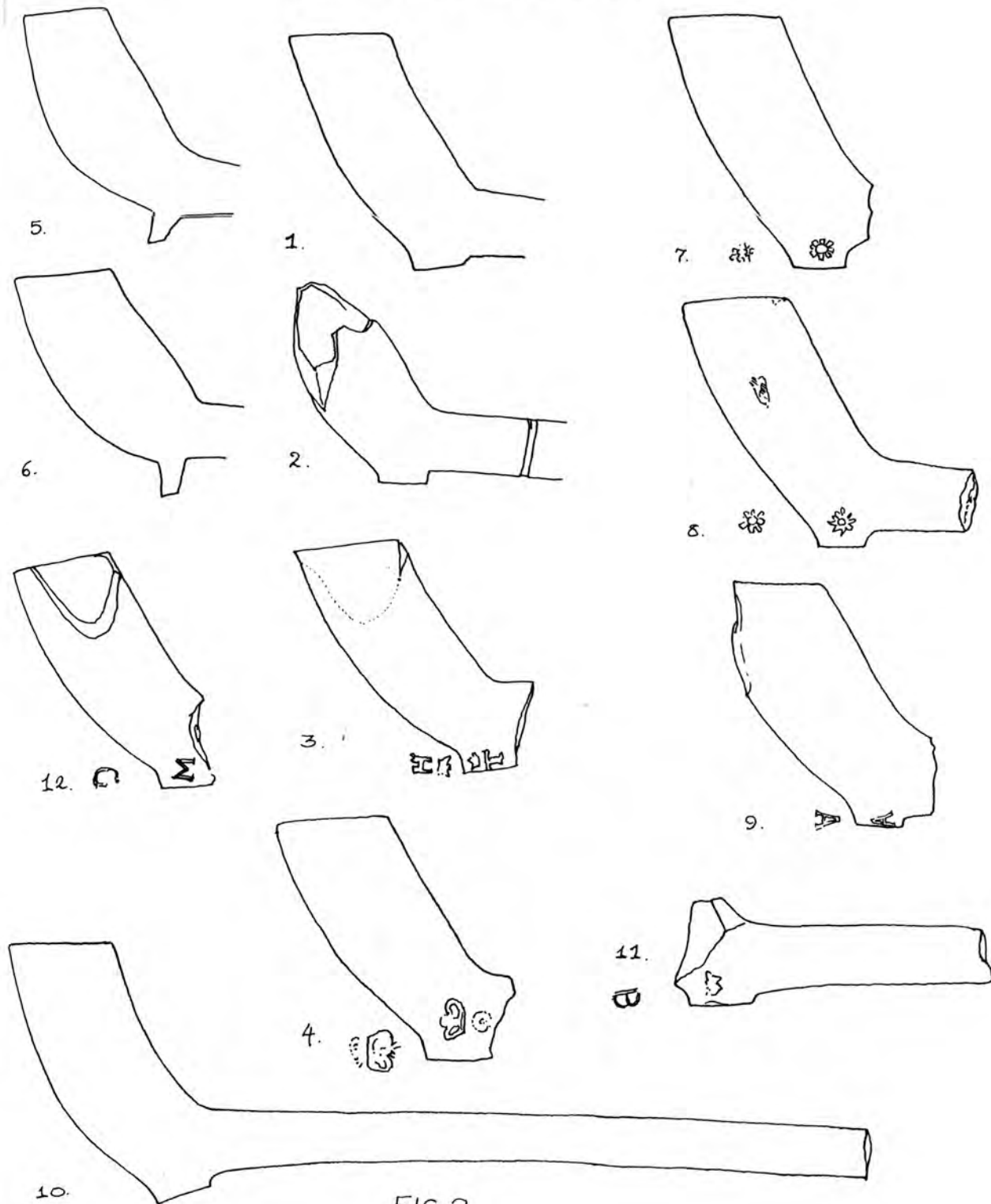

FIG. 2.

BLACKFRIARS to DOWGATE. (N. BANK.)
R. THAMES.

1/1 - C.1690 to 1730.

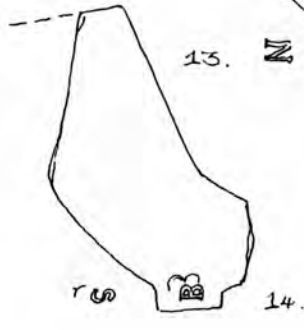
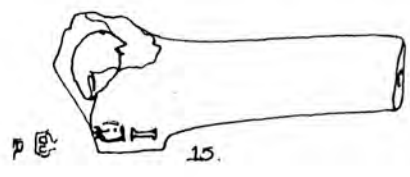
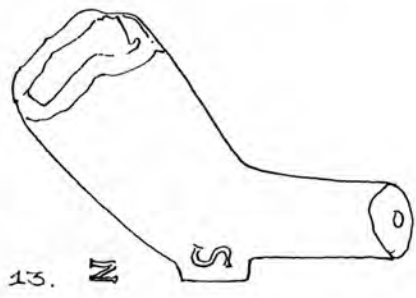
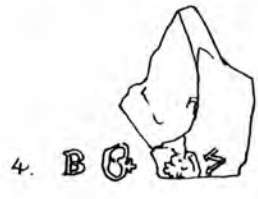
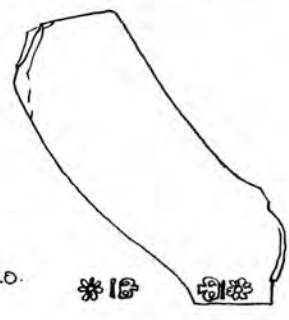
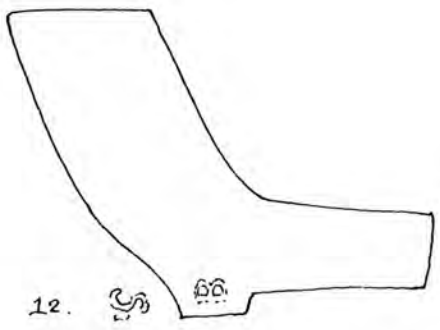
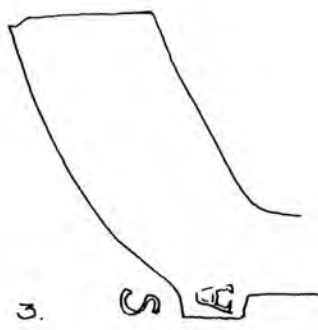
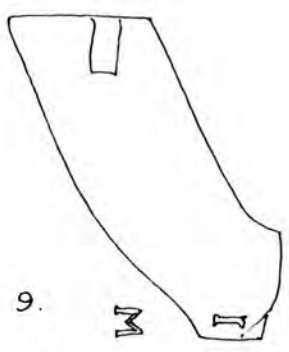
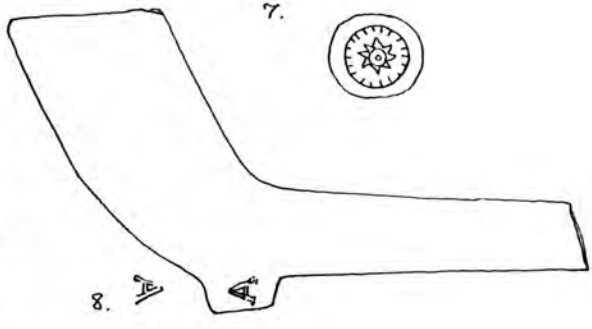
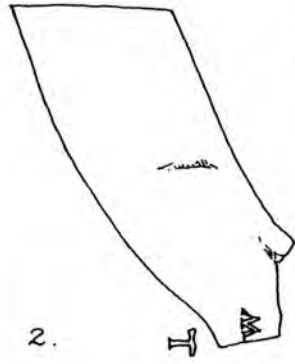
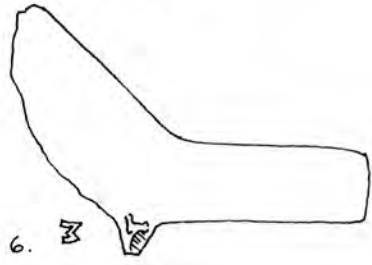
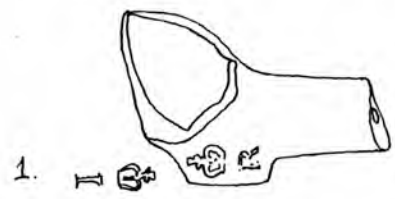
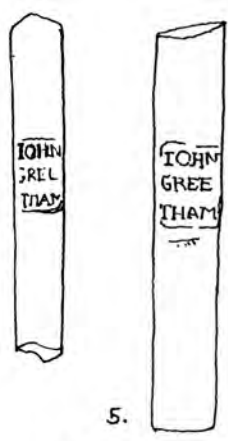

FIG. 3.



BLACKFRIARS to DOWGATE (NORTH BANK).

R. THAMES.

1/1 - C. 1690 to 1730.

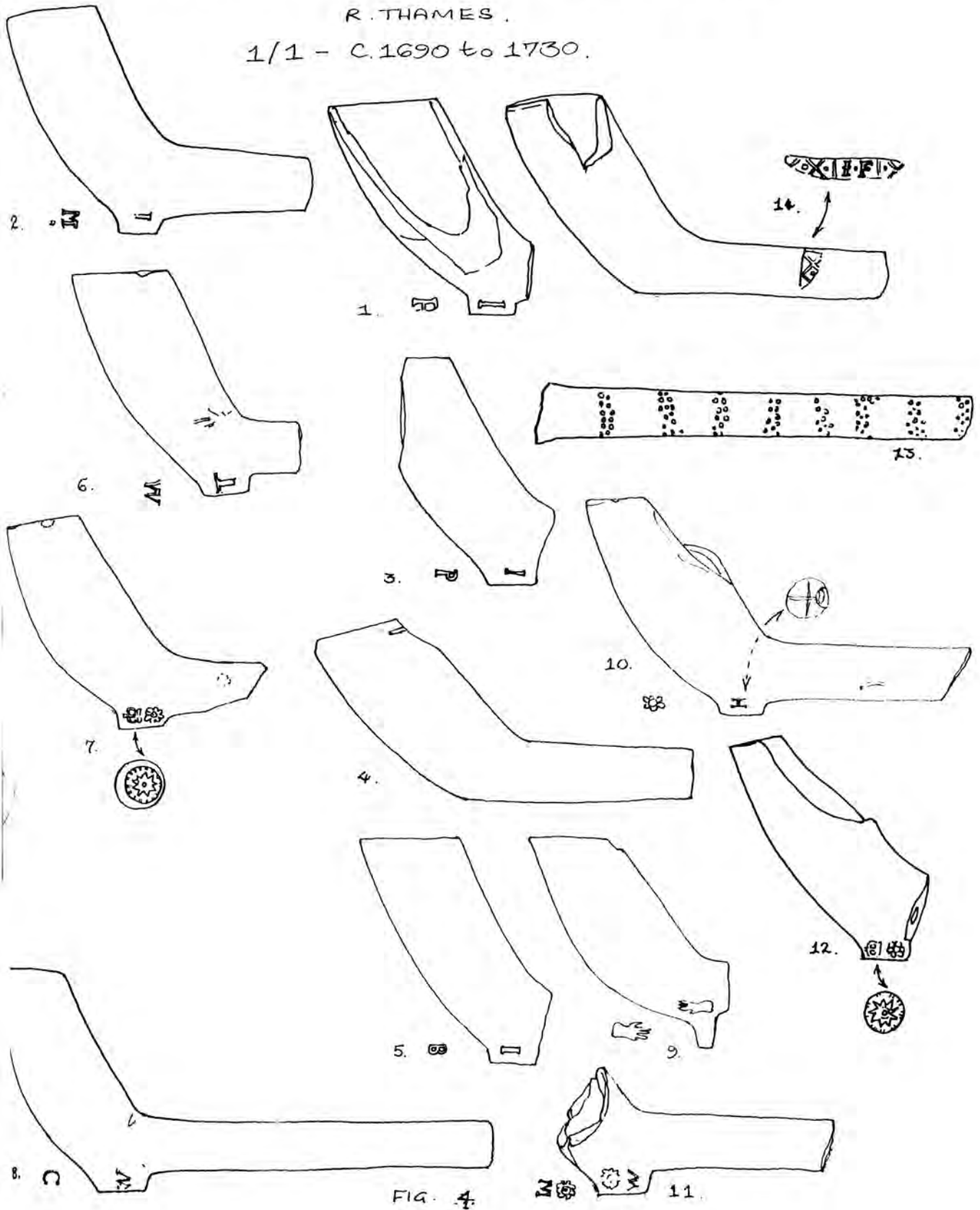

FIG. 4

FIG. 1.

1. (20.9.82.)

C. 1690-1730.

S.B.D. 3 MM. LIP R.H.S. - CHIPPED.

ROULETTING BACK OF BOWL LIP. VERY STOCKY SPUR WITH FLATTENED, OVAL BASE. BECAUSE OF THE ROULETTING AND SLOPING MOUTH PROBABLY MADE IN THE EARLY PART OF THIS PERIOD.

2. (AUTUMN 1982)

C. 1690-1730

S.B.D. 2.7 MM. LIP CHIPPED L.H.S.

GREY CLAY WITH SPECKLED INCLUSIONS. ROULETTING BACK OF BOWL LIP. VERY STOCKY SPUR WITH FLATTENED, OVAL BASE. SURFACE FAIRLY SMOOTH AND SHINY. THIS BOWL SHOWS MORE OF THE FLAIED, WEST COUNTRY TYPE CHARACTERISTICS THAN NUMBER ONE. AGAIN, BECAUSE OF THE ROULETTING, S.B.D. AND SLOPING BOWL MOUTH PROBABLY MADE IN THE LATE 17th.

3. (20.9.82.)

C. 1690-1730.

S.B.D. 2.2 MM. GREY SURFACE STAINED DARKER

R.H.S. BOWL CAVITY WHITE. MOUTH - WIDE. LARGE STOCKY SPUR WITH FLATTENED BASE. POSSIBLY LATER THAN NUMBER ONE OR TWO.

4. (16.11.82.) - QUEENHITHE

C. 1690-1730.

L. TYPE 23. S.B.D. 2.75 MM. LIP CHIPPED BACK/L.H.S. LIGHT FAWN

CLAY, SMOOTH. POINTED SPUR, FORWARD SLOPING. BASICALLY A WILTSHIRE SHAPE



FIG. 1.

5. (16.11.82.) - QUEENHITHE.

C. 1700-30. L. TYPE 23. S.B.D. 2 MM. LIP BROKEN L.H.S. WHITISH CLAY, SOME IRON STAINING L.H.S. GAUNTLET MARKS MOULDED IN RELIEF EACH SIDE OF SPUR. SIMILAR TO BAR 97, P. 141 NO. 80 AND P. 167 NO. 39. PROBABLY A LONDON PSEUDO-WILTSHIRE TYPE.

6. (3.10.82.)

C. 1700-30. L. TYPE 25. S.B.D. 2.4 MM. CLAY, SHINY AND SMOOTH, OFF WHITE/MUSHROOM. SMOKE STAINED INSIDE CAVITY. BOWL - 'DROPPED.' OVAL BASE. 'W' AND 'T'? AT BOWL BASE, L.H.S. AND R.H.S.

7. (3.1.83.) - PAULS WHARF.

C. 1700-20. S.B.D. 2.75 MM. CLAY, OFF-WHITE/CREAM. BASE-OVAL. STEM LENGTH FROM BACK OF BASE TO BREAK - 102.75 MM.

8. (6.10.82.)

C. 1700-20. L. TYPE 25. S.B.D. 2.5 MM. CLAY - WHITISH. LIP CHIPPED. RUST INSIDE CAVITY. GROOVE BACK OF BOWL LIP. 'A' L.H.S. HEEL. 'A' R.H.S. BASE - OVAL. POSSIBLY ANTHONY ANDREWS (ARTHUR) 1694-1716 F.J. BRYANT HIS APP. #5. SURREY REC. SOC.



FIG 1.

9. (21. 11. 82) - QUEENHITHE

C. 1700-30. L. TYPE 25. S. B. D. 2.5 MM. MOTTLED, WHITE CLAY. BASE - OVAL
'W' L. H. S. 'B' R. H. S. HEEL.

10. (3. 12. 82) - QUEENHITHE

C. 1700-30. L. TYPE 25. S. B. D. 2.3 MM CREAM/GREY CLAY, BLUE/GREY STAINS
FRONT OF BOWL. MOULD LINE FRONT OF BOWL. SLIGHTLY SPLAYED, ROUND HEEL.
LIP - FLAT AND THICK. 'G'/'B' IN RELIEF STAMPED JUST TO THE RIGHT OF
BACK OF BOWL.

11. (13. 5. 83.) QUEENHITHE.

C. 1700-30. L. TYPE 25. S. B. D. 2.6 MM. NARROW, UPRIGHT BOWL, SQUARISH
BASE. MAKER I/B. LETTERS IN DEEP RELIEF. SMALL. A NUMBER OF POSSIBLE
MAKERS INCLUDING: JOHN BAYLEY, 1719-31, ST. BOTOLPHS.

12. (25. 3. 83.) PAUL'S WHARF.

C. 1700-30. L. TYPE 25. S. B. D. 2 MM. LARGE, NARROW, UPRIGHT BOWL,
TAPERING TO OVAL, SQUARE BASE. MAKER: I/S. THICK STEM. A NUMBER
OF POSSIBLE MAKERS.

13. (14. 4. 83.) QUEENHITHE.

C. 1700-30. S. B. D. 2.5 MM. STEM PIECE (GREY) WITH PART OF
BASE AND ROULETTING AROUND STEM.



FIG. 2.

1. (LATE 1982)

C. 1700-30. L. TYPE 25. S.B.D. 2.5 MM. CLAY - SMOOTH, POLISHED, OFF-WHITE. HEEL - 'DROPPED', ROUND.

2. (21.11.82.)

C. 1700-30. L. TYPE 25. S.B.D. 2.6 MM. CLAY - OFF-WHITE. BOWL, BROKEN. HEEL - SQUAT AND ROUND. GROOVING ROUND STEM ABOUT 18 MM FROM BOWL.

3. (3.12.82.) PAULS WHARF.

C. 1700-30. L. TYPE 25. S.B.D. 2.5 MM. CLAY - OFF-WHITE/PALE BUFF. BOWL BROKEN-BACK, R.H.S. SMOKE-STAINED INSIDE CAVITY. BASE - ROUND. 'T' L.H.S. WITH CORONET ABOVE. 'H' R.H.S., CORONET ABOVE.

4. (17.12.82) PAULS WHARF.

C. 1700-30 L. TYPE 25. S.B.D. 2.5 MM. CLAY - PALE PINK/BUFF. IRON STAINING. LARGE ROUND BASE, SPLAYED. CROWN L.H.S. WITH POSSIBLY 'O' CROWN R.H.S. WITH UNIDENTIFIED LETTER.

5. (31.1.83.) QUEENHITHE.

C. 1690-1730. L. TYPE 23. S.B.D. 2.6 MM. GREYISH CLAY. SMOKE STAIN R.H.S. CHEEK, AND INSIDE LIP CAVITY. POINTED, FORWARD CUT SPUR.

FIG. 2

6. (7.6.83) QUEENHITHE.

C. 1690-1730. L. TYPE 23. S.B.D. 2.2 MM. JUG-SHAPED BOWL, SMOKE STAINED LIP. UPRIGHT SPUR, TRUNCATED OBLIQUELY IN PROFILE. BURNISHED SURFACE. TOP OF BOWL PARALLEL TO STEM, PROBABLY DATING THE PIPE AROUND OR AFTER 1700. GREYISH/FAWN CLAY.

7. (15.8.83) QUEENHITHE

C. 1710-30. L. TYPE 25. S.B.D. 2.6 MM. TALL, GREYISH BOWL, WITH PARALLEL SIDES, LARGE, ROUND BASE WITH FLOWERHEAD MOTIFS EACH SIDE. CHIP, R.H.S. OF LIP.

8. (15.8.83) QUEENHITHE.

C. 1710-30. L. TYPE 25. S.B.D. 2.13 MM. SIMILAR TO NO. 7. BASE ROUND AND SHALLOW. LARGE FLOWERHEADS EACH SIDE. DULL OFF-WHITE FABRIC.

9. (15.8.83) QUEENHITHE.

C. 1710-30. L. TYPE 25. S.B.D. 2.1 MM. BOWL OF DULL WHITE FABRIC. SHALLOW OVALAR BASE. MAKER A/A. ANTHONY ANDREWS 1694-1716. OR ANTHONY ATKINSON 1696. O.A. (J).

10. (12.8.83) SOUTHWARK BRIDGE/DOWGATE.

C. 1700-10. L. TYPE 25. S.B.D. 2.2 MM. TALL, NARROW BOWL, SLIGHTLY FLARED LIP. BASE -, CONCAVE AND DOWNWARD SLOPING. BOWL THICK IN SECTION LENGTH OF STEM FROM BACK OF BASE TO BREAK: 102 MM.

11. (10.8.84) QUEENHITHE.

C. 1700-30. L. TYPE 25. S.B.D. 2.1 MM. CREAMY STEM/BASE; ALGAE ON SURFACE. LARGE OVAL BASE; ROUND STEM-BREAK-CENTRAL BORE; MAKER W/B. SEVERAL POSSIBILITIES.

12. (12.10.84)

C. 1700-30. L. TYPE 25. S.B.D. 2.6 MM. NARROW, DISCOLOURED BOWL; SHINY SURFACE; M/G? SIDES OF BASE. MOSES GEE, 1681-96. F. O.A. YINTRY. S. MARTINS.

FIG. 3.

- 1. (6.10.82.)
C. 1700-30. L. TYPE 25. BASE/STEM FRAGMENT. LARGE OVAL BASE, CROWNED INITIALS EACH SIDE: R / I. POSSIBLY RICHARD JOHNSON (2) 1693 (F); OR, RICHARD JONES (1) 1696.

- 2. (7.6.83.) QUEENHITHE.
C. 1700-30. L. TYPE 25. S. B. D. 2.2 MM. VERY THICK, TALL BOWL, MUSHROOMY FAWN IN COLOURING. SHINY SURFACE. OVAL BASE. MAKER: W/T. POSSIBLY SAME MAKER AS FIG. 1. NO. 6.

- 3. (7.6.83.) QUEENHITHE.
C. 1720-30. L. TYPE 25. S. B. D. 2.4 MM. THICK BOWL AND STEM. CYLINDRICAL SPUR. VERY LARGE A/S. POSSIBLY ABRAHAM SHEPHARD, 1721 OR ABRAHAM SANDS, 1725. F. A THIRD, PERHAPS MORE UNLIKELY MAKER, COULD BE ANTHONY SIDEWELL, 1696-1704.

- 4. (9.8.83.) QUEENHITHE.
C. 1710-30. L. TYPE 25. S. B. D. 2.5 MM. BASE FRAGMENT, THICK BOWL SECTION, DULL, GREYISH CLAY. SQUAT, ROUND BASE, INITIALED W/B WITH CROWNS. THE LETTER 'B' IS UNUSUALLY VERTICAL. POSSIBLY MADE BY WILLIAM BURGESS, 1718, APP. TO R. MANBY, OR WILLIAM BRAY, 1719, APP. THE SAME.

- 5. (5.10.83.) DOWGATE.
C. 1700-30. S. B. D. 2.75 MM. INCISE STEM STAMP: JOHN GREETHAM. ATKINSON, MAKERS' MARKS... 1962, P. 185, RECORDS SIMILAR BUT SPELT GREITHAM. ALSO LISTED BY OSWALD WITH THIS SPELLING. DOUBTLESS BOTH WERE MADE BY THE SAME HANDS. AT THIS TIME, SURNAMES WERE STILL LIABLE TO BE WRITTEN PHONETICALLY.

- 6. (29.9.83.) DOWGATE.
C. 1730. S. B. D. 2.3 MM. BROKEN BOWL WITH SMALL SPUR LETTERED T?/M. PERHAPS THOMAS MORTIMER (2) 1720, FATHER. UNCOMMON.

FIG. 3.

7. (NOVEMBER 1983). BROOK'S WHARF.

C. 1700-30. S.B.D. 2.1 MM. NARROW, UPRIGHT BOWL WITH ROUND MOUTH. MEDIUM THICK. BROWNISH-GREY. BASE STAMP OF STAR IN RELIEF WITHIN CIRCLE DEPRESSION. CROWNS AND STARS ALSO ON SIDES OF BASE.

8. (24.10.83.) QUEENHITHE.

C. 1710-20. S.B.D. 2 MM. THICK STEM. R.H.S. BOWL LIP BROKEN. SEMI-SHINY SURFACE. A/A ON SPUR. SEAM LINE ON BASE. MAKER: ANTHONY ANDREWS (ARTHUR) 1694-1716, OR ANTHONY ATKINSON, 1696. O.A. (J).

9. (20. 1. 84.) SOUTHWARK BRIDGE/DOWGATE.

C. 1710-30. L. TYPE 25. S.B.D. 2.5 MM. TALL, UPRIGHT, GREYISH BOWL, SMOKE STAINS IN CAVITY. CHIP L.H.S. RIM. CHIPPED BASE. MAKER I/M. PERHAPS JOHN MALLETRAT, 1701. F.; JOHN MASON, 1706, F.

10. (20. 1. 84.) QUEENHITHE.

C. 1690-1710. L. 21. S.B.D. 2.85. THICK, NARROW DISCOLOURED BOWL, FRONT LIP CHIPPED, BROWN CAVITY. BROAD BASE WITH CROWNED FLOWERHEADS ON SIDES. RIM IS SLOPING DOWN FROM STEM AXIS, A COMMON FACTOR OF PRE-1700 BOWLS. Cf. NO. 7.

11. (5.5.84.) BROOK'S WHARF.

C. 1700-30. S.B.D. 2.2 MM. JOHN GREETHAM STAMPED STEM, APPARENTLY NO. 6. STEM IS THICKER, FRACTIONALLY. SEE NO. 5 FOR REMARKS.

12. (5.5.84.) SOUTHWARK BRIDGE/DOWGATE.

C. 1710-30. L. TYPE 25. S.B.D. 2 MM. SMOKED, MEDIUM THICK BOWL, LIP LEVEL; ROUND, THICK STEM, CENTRAL BORE; IRON STAINS; SMALL, CYLINDRICAL BASE. MAKER B/S. NEAR S INDICATIONS OF PREVIOUS LETTER? EITHER BENJAMIN SKEATS, 1696 O.A. (J). IF WORKING IN (18th LONDON (SEE SUFFOLK, OS. 1975) OR BENJAMIN STEPHENSON, 1713 F.

FIG. 3.

13. (12.9.84)

C. 1710-30. L-TYPE 25. S.B.D. 2.05 MM. THICK, SMOKED, LIGHT-MUSHROOM FABRICED BOWL; SQUARISH BASE; ROUND STEM BREAK; LARGE S/N ON SIDES; PERHAPS: SAMUEL NODWELL, 1701, F. J. KINGSLEY HIS APP.; OR SAMUEL NUNN, 1726. APP. R. APP. TO J. BAYLEY. £ 4. PERHAPS THE FORMER, WHO WAS ALREADY A MASTER P. MAKER BETWEEN 1710-30.

14. (24.2.85)

C. 1710-30. L-TYPE 25. S.B.D. 2.1 MM. SHORT, GREY, THICK BOWL; SMOOTH OVAL BASE; MAKER B/S. OTHER LETTERS BELOW B/P. SEE NO. 12.

15. (7.12.1986) QUEENHITHE/SOUTHWARK BDCG.

C. 1700-30, L-TYPE 25. S.B.D. 2.6 MM. ROUND STEM-BREAK, CENTRAL BORG; I/R MAKER. PERHAPS JOHN ROBERTSON, 1721, SOUTHWARK, CHILD BAPTISED (OS. IN LIT. 1986) OR JOHN REYNOLDS (2), 1718-30, FREE, BAPTISED CHILD. P. REGS. ST. GEORGE IN THE EAST (OS. 1975). 1732 BAPTS. THOMAS, (JOHN REYNOLDS FATHER), BY MARY, IN KING ST. DIED IN 1754, 20th AUG. (ST. GEORGE'S BURIALS) C.A.T. 1985 RESEARCH. SIMILAR CROWNED I/R MKS. FROM WAPPING, SO COULD BE THIS MAKER.

FIG. 4.

1. (12.10.84.)

C. 1690-1730. L-TYPE 25. S.B.D. 2.05 MM. SMOKED, THICK BOWL; LIP SLIGHTLY FORWARD SLOPING; OVAL SPUR; I/R BY SIGGS; A NUMBER OF POSSIBLE MAKERS.

2. (8.11.84.)

C. 1700-30. L-TYPE 25. S.B.D. 2.75. THICK, UPRIGHT BOWL; CHIP L.H.S. OF LIP; DAPPLED STAINS ON FRONT; MAKER I/M. SEE FIG. 3, NO: 9.

3. (8.11.84.)

C. 1700-30. L-TYPE 25. S.B.D. 2.45 MM. THICK, IRON STAINED BOWL; FLAT, ROUND BASE; MAKER I/P. SEVERAL POSSIBLES: PERHAPS JOHN PINKARD (1), 1703 F; OR J. PINKARD (2) F IN 1732.

4. (8.11.84.) SOUTHWARK BRIDGE.

C. 1690-1720. S.B.D. 2.5 MM. IRON STAINED SPUR OR BASE-LESS PIPE; TRACE OF GROOVE OR MILLING ON BACK; ROUND, IRON-STAINED STEM - THICK; Cf S.C.P.R.N. 4 PAGE 10, IN EXCAVATIONS DATED C. 1700-20. TYPICAL OF THOSE EXPORTED TO AMERICA.

5. (1985).

C. 1710-30. L-TYPE 25. S.B.D. 2 MM. TALL, NARROW BOWL; SMOOTH SURFACE; OVAL BASE; I/B MAKER. SEE FIG 1, NO. 11.

6. (2.7.85.) PAUL'S WHARF.

C. 1710-40. L-TYPE 25. S.B.D. 2.5 MM. MEDIUM-THICK FABRIC; ROUND STEM-BREAK, CENTRAL BORE; OVAL BASE WITH 'SCRAPED' LINES; T/W MAKER. A NUMBER OF POSSIBLES LISTED BY OSWALD (1975).

7. (23.3.1986) QUEENHITHE.

C. 1700-30. L-TYPE 25. 2.5 MM. MEDIUM BOWL; CREAMY (DULL) SURFACE; 'ROSE AND CROWN' ON SPUR SIGGS; RELIEF STAR ON BASE. DUPLICATES FIG. 3 NO 7.



FIG. 4.

8. (13.6.1986) QUEENHITHS/SOUTHWARK BRIDGE.

C. 1700-20. L. TYPE 25. S.B.D. 2 MM. TALL, RATHER ELEGANT PIPE BOWL; BURNISHED SEAMS; W/C MAKER. A NUMBER OF POSSIBLES.

9. (7.12.1986).

C. 1700-30. S.B.D. 2.13 MM. CHIPPED, SMOKED BOWL. A SVEDD-WILTSHIRE TYPE? SEE FIG. 1 ABOVE, NO. 5.

10. (1.12.1986)

C. 1710-30. L. TYPE 25. S.B.D. 2.05 MM. DISCOLOURED BOWL. INTERNAL BOWL CROSS (USUALLY COMMON C. 1720+) THICK STEM. H/ FLOWERHEAD ON SPUR. UNCOMMON. AN E/ FLOWERHEAD IS KNOWN FROM WATERLOO, SEE CAT.

11. (6.1.1987)

C. 1710-30. S.B.D. 2.08 MM. STAIRS IN CAVITY BASE; OVAL BASE; OVAL STEM-BREAK, CENTRAL BORE; OFF WHITE CLAY; W/M WITH FLOWERHEADS ON SIDES OF BASE. W/M MORE USUALLY FOUND WITH CROWNS. SEE FILE BOX FOR NOTES ON THE MANBY'S.

12. (14.9.1987)

C. 1700-1730. S.B.D. 2.5 MM. SMOKED CAVITY; BURNISHED, GRAY SURFACE. CF. NO. 7.

13. (14.9.1987)

EARLY-MID 18th C? S.B.D. 2.4 MM. BANDS OF INCUSE PELLETS, HAND APPLIED. ORIGIN UNKNOWN.

14. (8.10.1987)

C. 1690-1720. S.B.D. 2.5 MM. 'FUNNEL' SHAPED PIPE; " I/F MARK IN RELIEF ON STEM. FOUND AT QUEENHITHS. OSWALD (IN LIT. 16.9.1987) REMARKS: OTHER E.G. ELKIN'S COLL.; ST. MARY'S CITY MARYLAND C. 1665-1740 (SITE); VIRGINIA C. 1700; LIGHTFOOT VIRGINIA 1680-1740; JAMESTOWN C. 1680-1700; IF STEM MARKS WITHOUT X OR DOTS AT MARLBORO', SWANSEA, OLD SWINDON, JAMES FOX 1692-1725 TROWBRIDGE?" SIMILAR BOWL SHAPE FROM POOLE EXCAVATIONS, ALSO WAPPING (SEE CAT.) ALSO CF. NO. 4 ABOVE. TYPICAL AMERICAN EXPORT TYPE.

BLACKFRIARS to DOWGATE. (N. BANK.)

R. THAMES.

1/1 - C1720 to 1780.

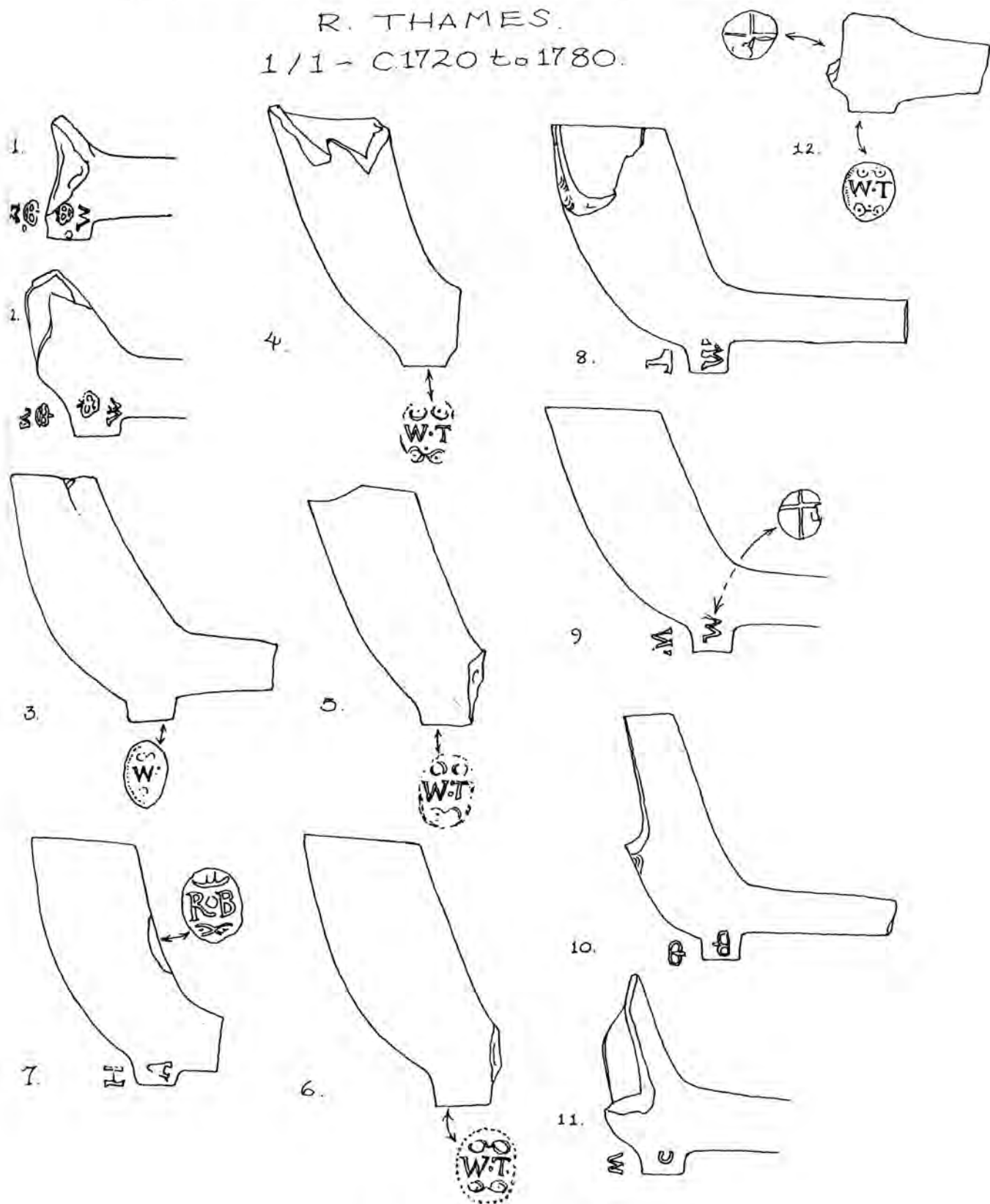

FIG. 1

BLACKFRIARS to DOWGATE (N. BANK.)

R. THAMES.

1/1 - C.1720 to 1780.

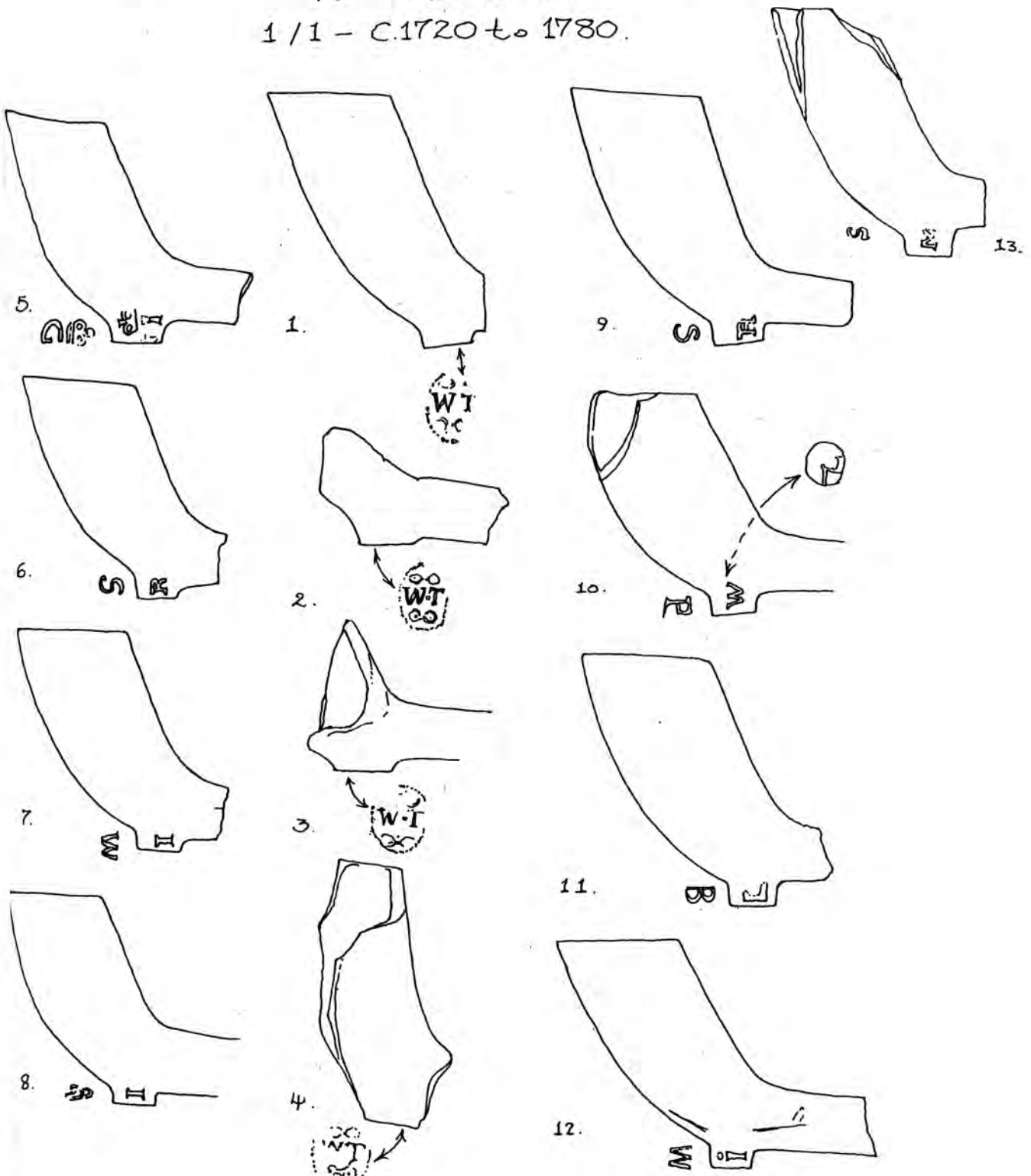

FIG. 2.

BLACKFRIARS to DOWGATE (N. BANK.)

R. THAMES.

1/1 - C.1720 to 1780.

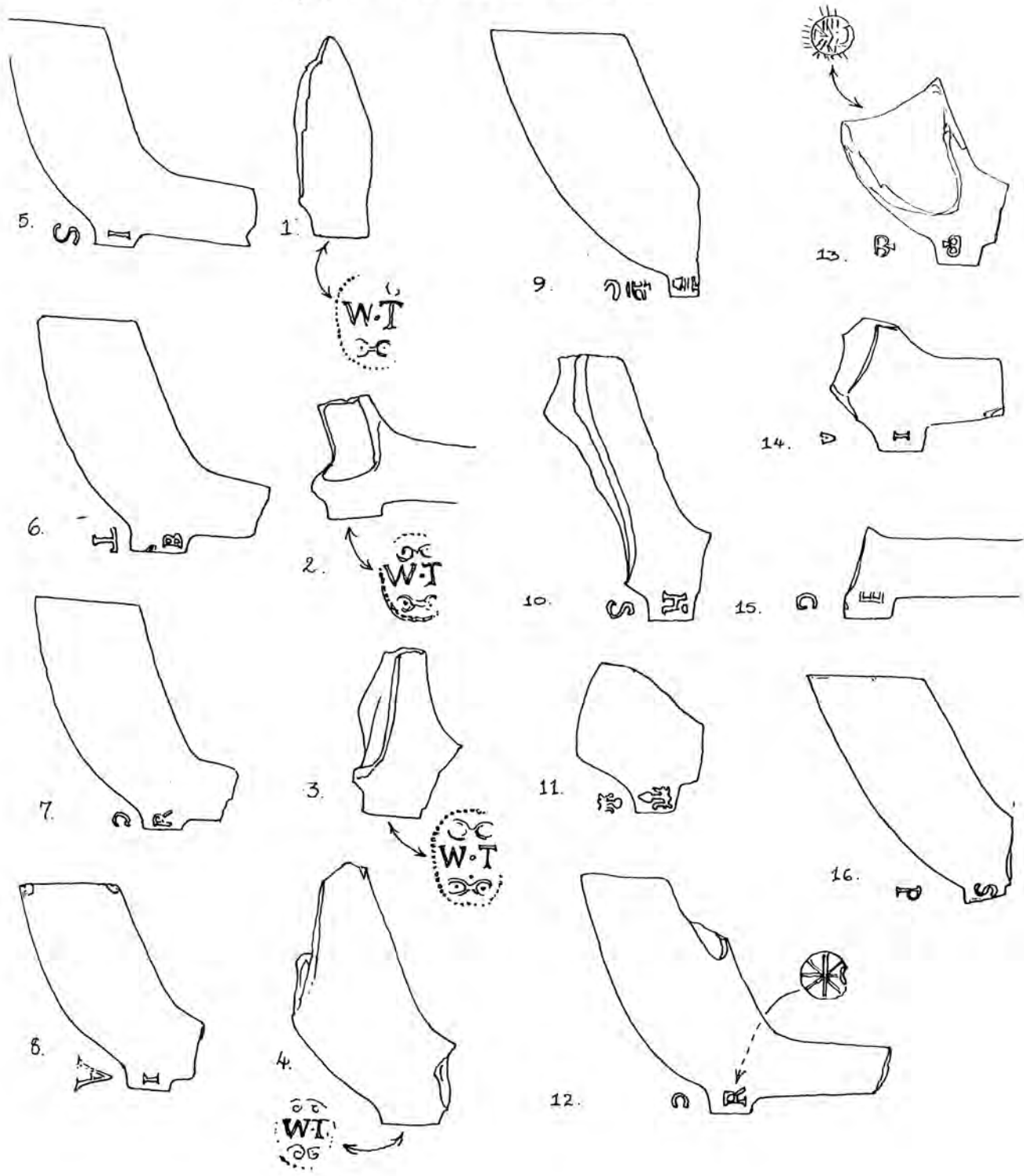

FIG. 3.

BLACKFRIARS to DOWGATE (N. BANK)

R. THAMES.

1/1 - C.1720 to 1780.

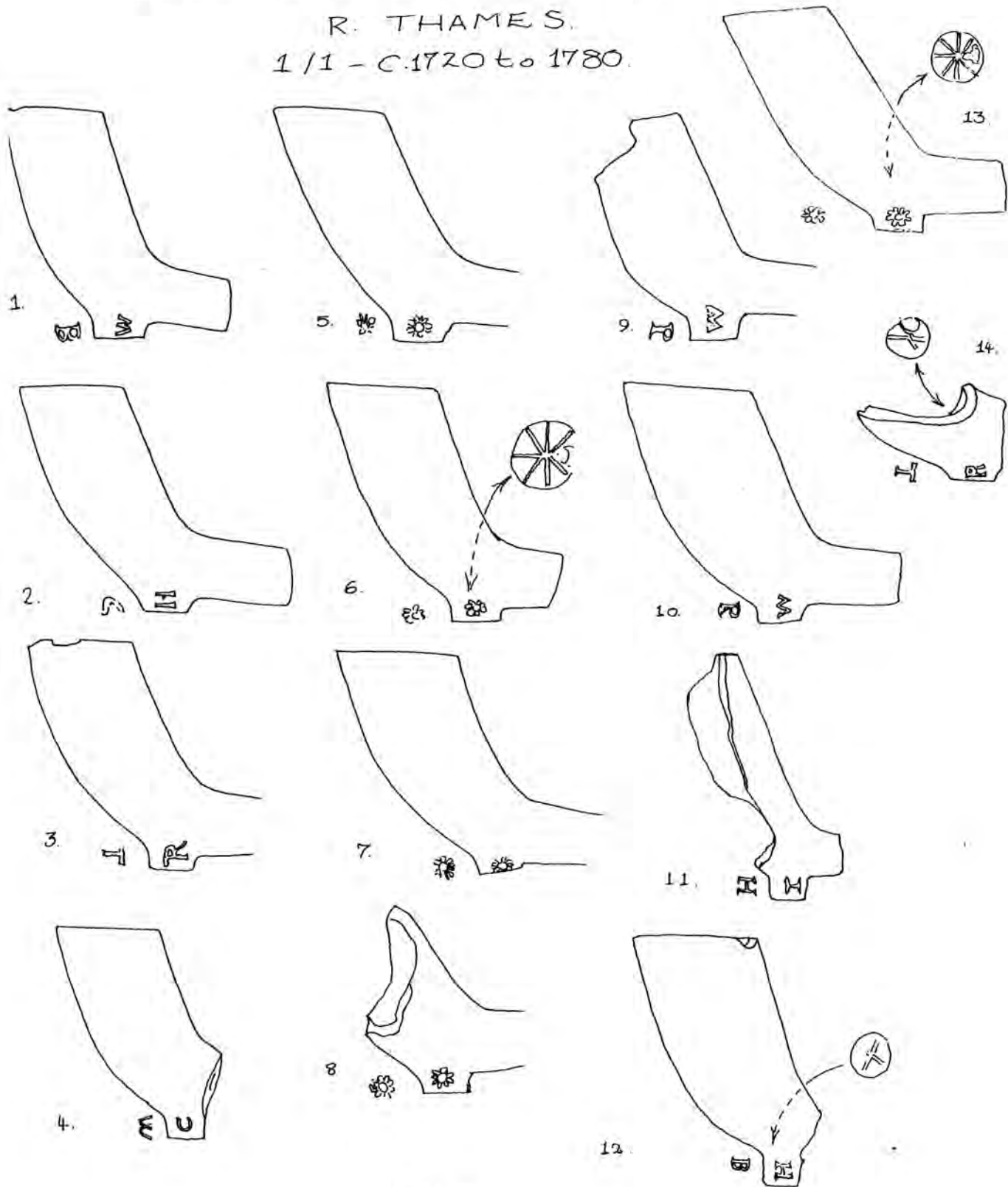

FIG. 4.

BLACKFRIARS to DOWGATE (N.BANK)

R. THAMES.

1/1 - C.1720-1780.

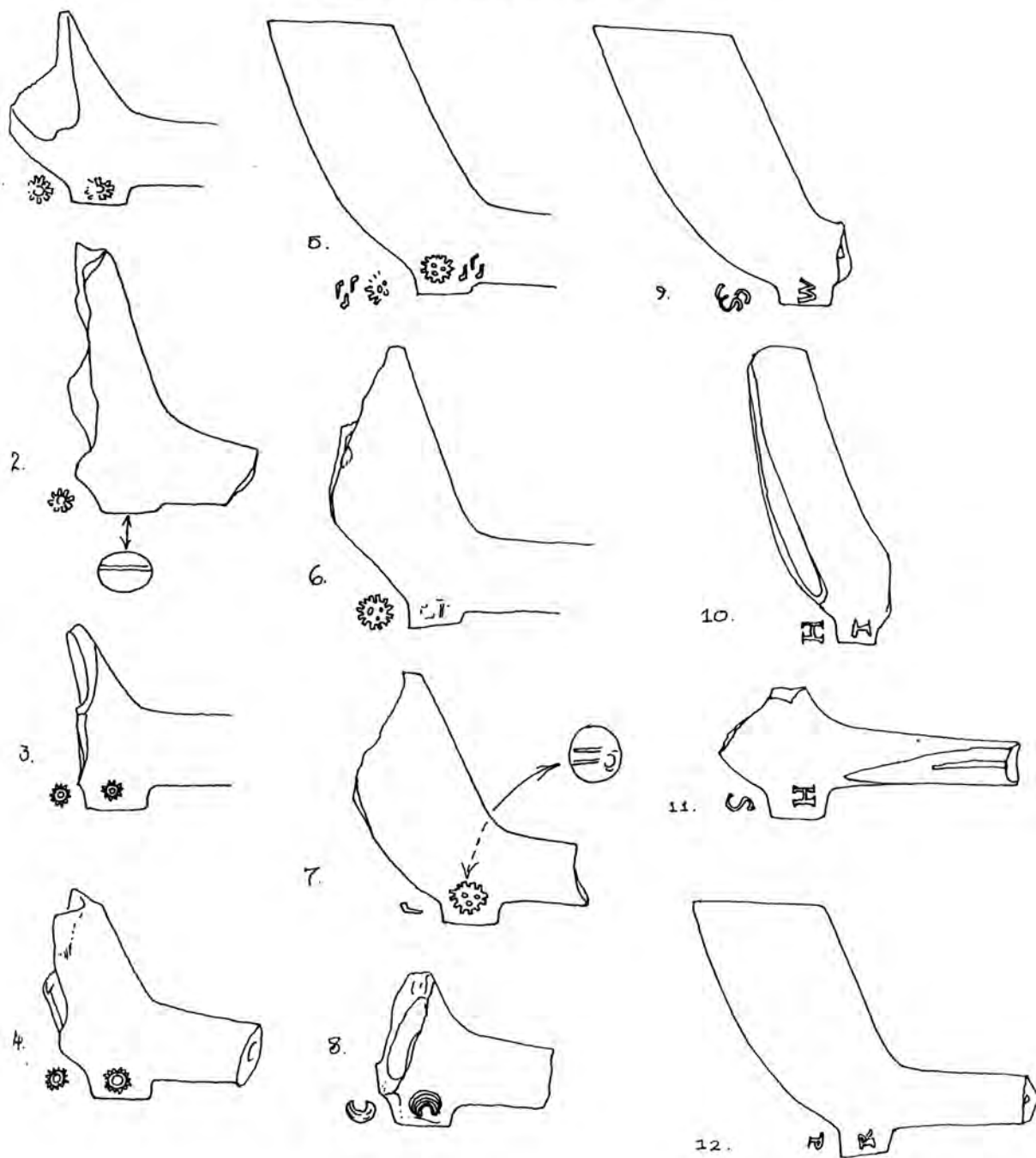

FIG.5

BLACKFRIARS to DOWGATE (N. BANK)

R. THAMES.

1/1 - C. 1720-1780.

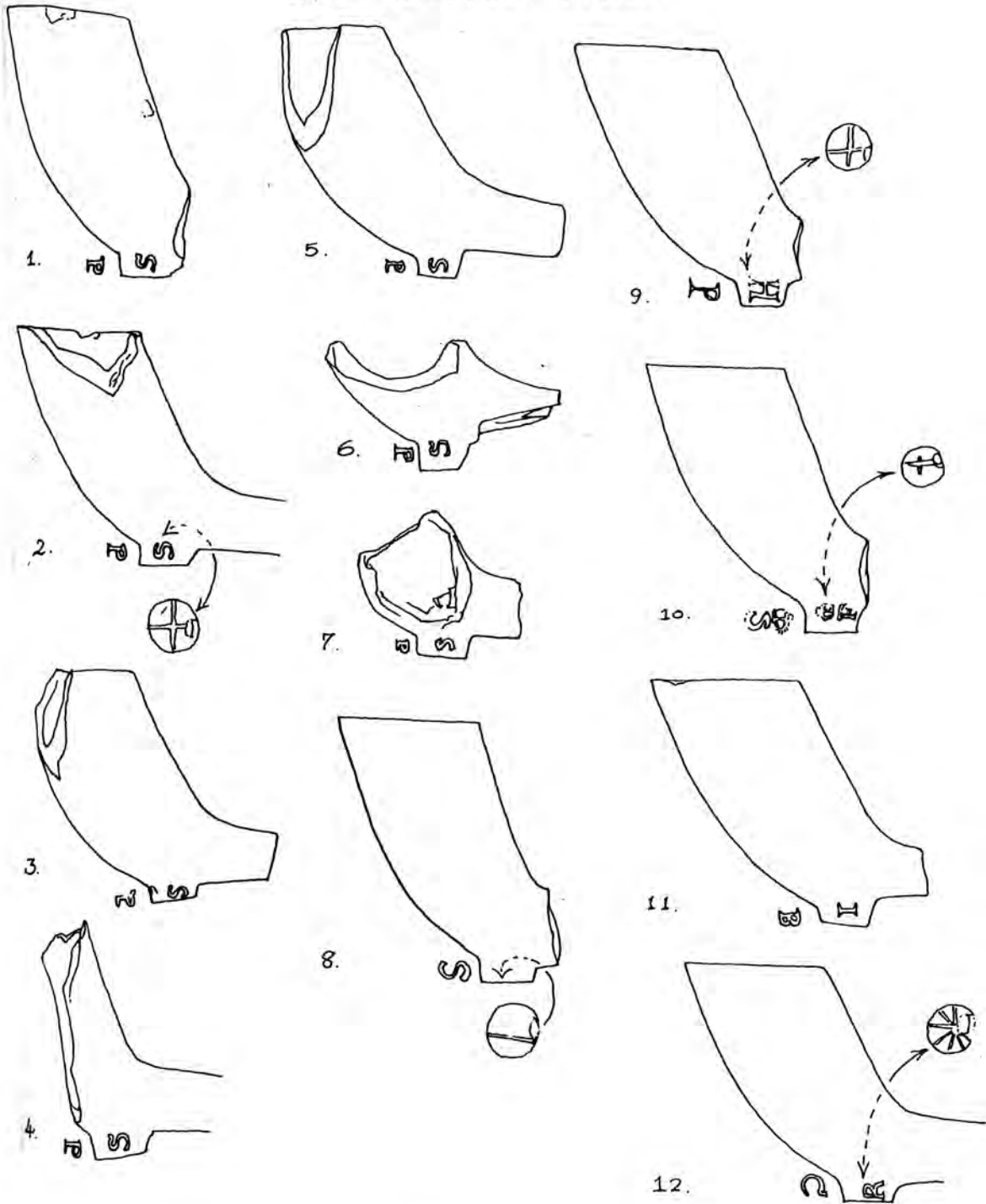

FIG. 6.

BLACKFRIARS to DOWGATE (N. BANK.)

R. THAMES.

1/1- C. 1720- 1780.

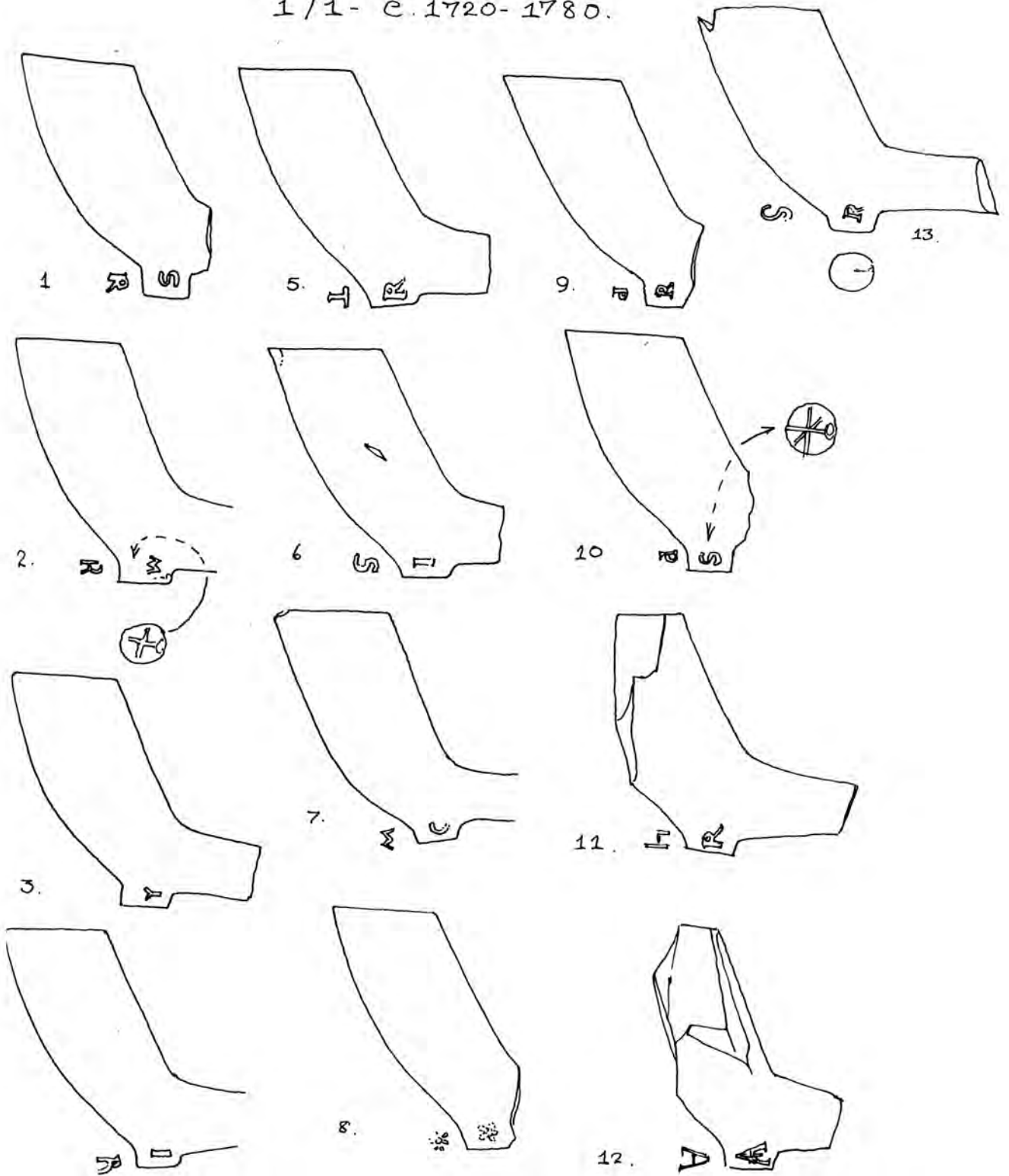

FIG. 7.



BLACKFRIARS to DOWGATE (N. BANK.)

R. THAMES.

1/1 - C.1720 to 1780.

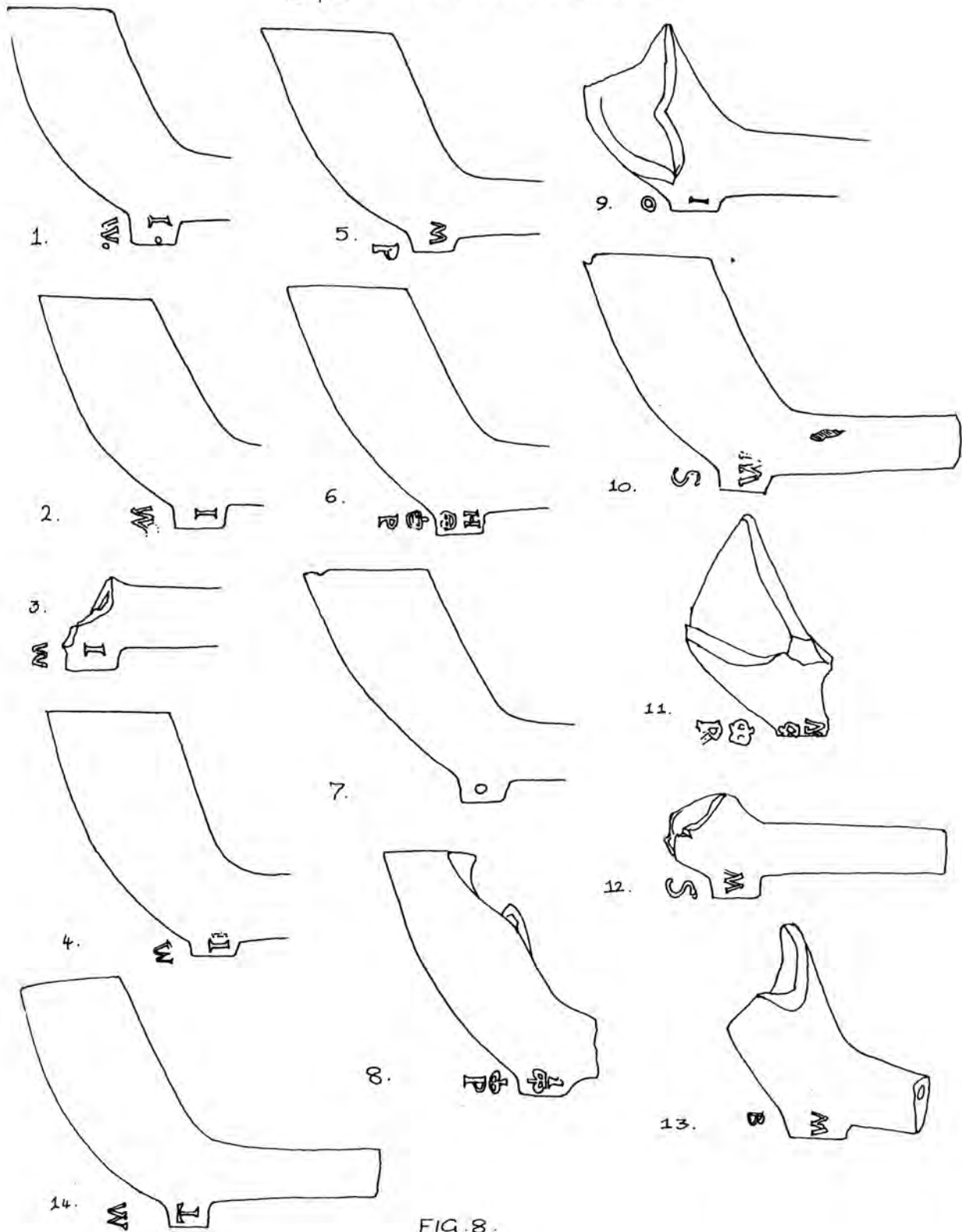

FIG 8.



BLACKFRIARS to DOWGATE (N. BANK.)

R. THAMES.

1/1 - C1720 to 1780.

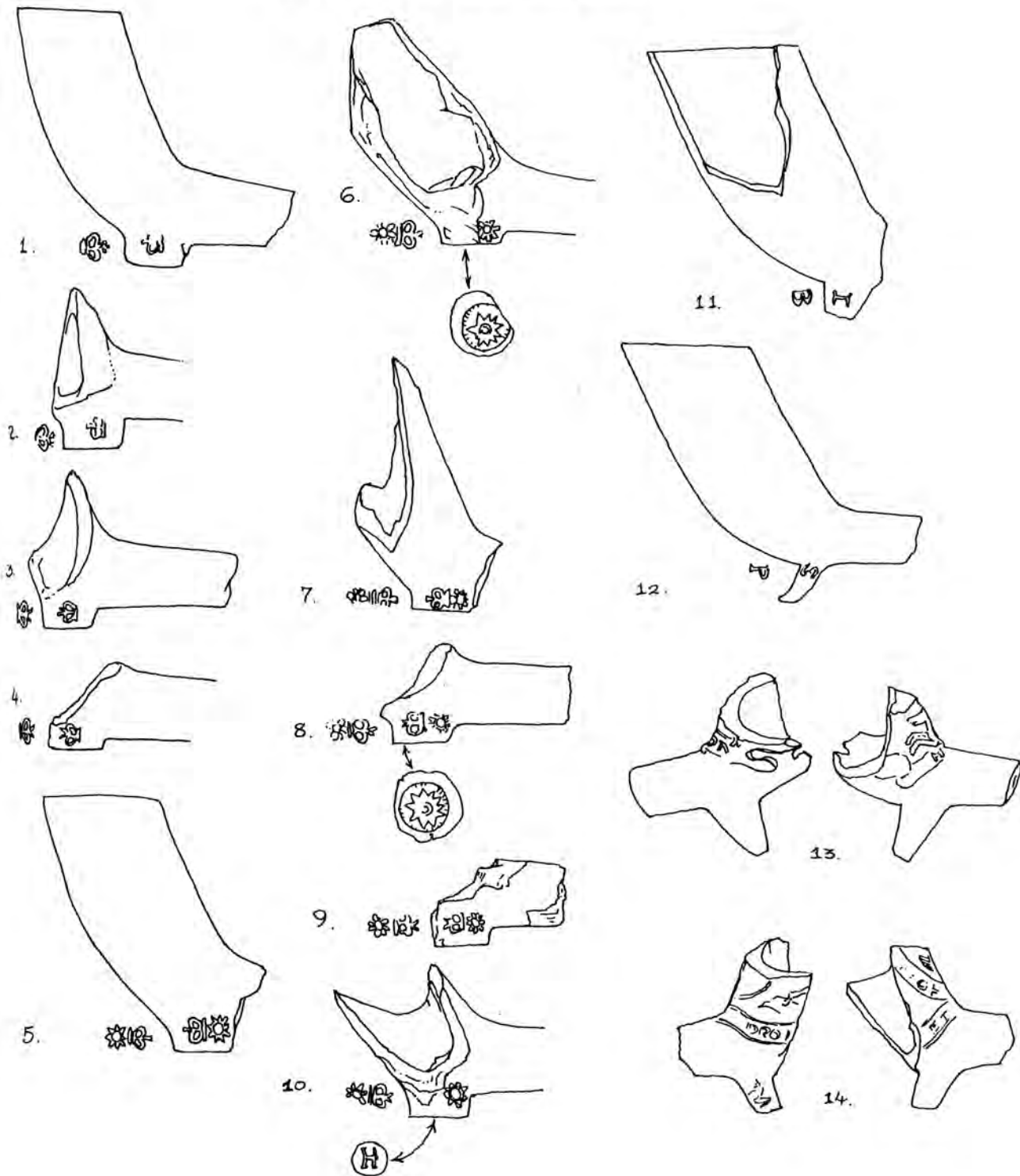

FIG. 9.

BLACKFRIARS TO DOWGATE (N. BANK.)

R. THAMES.

1/1 - C.1720 to 1780.

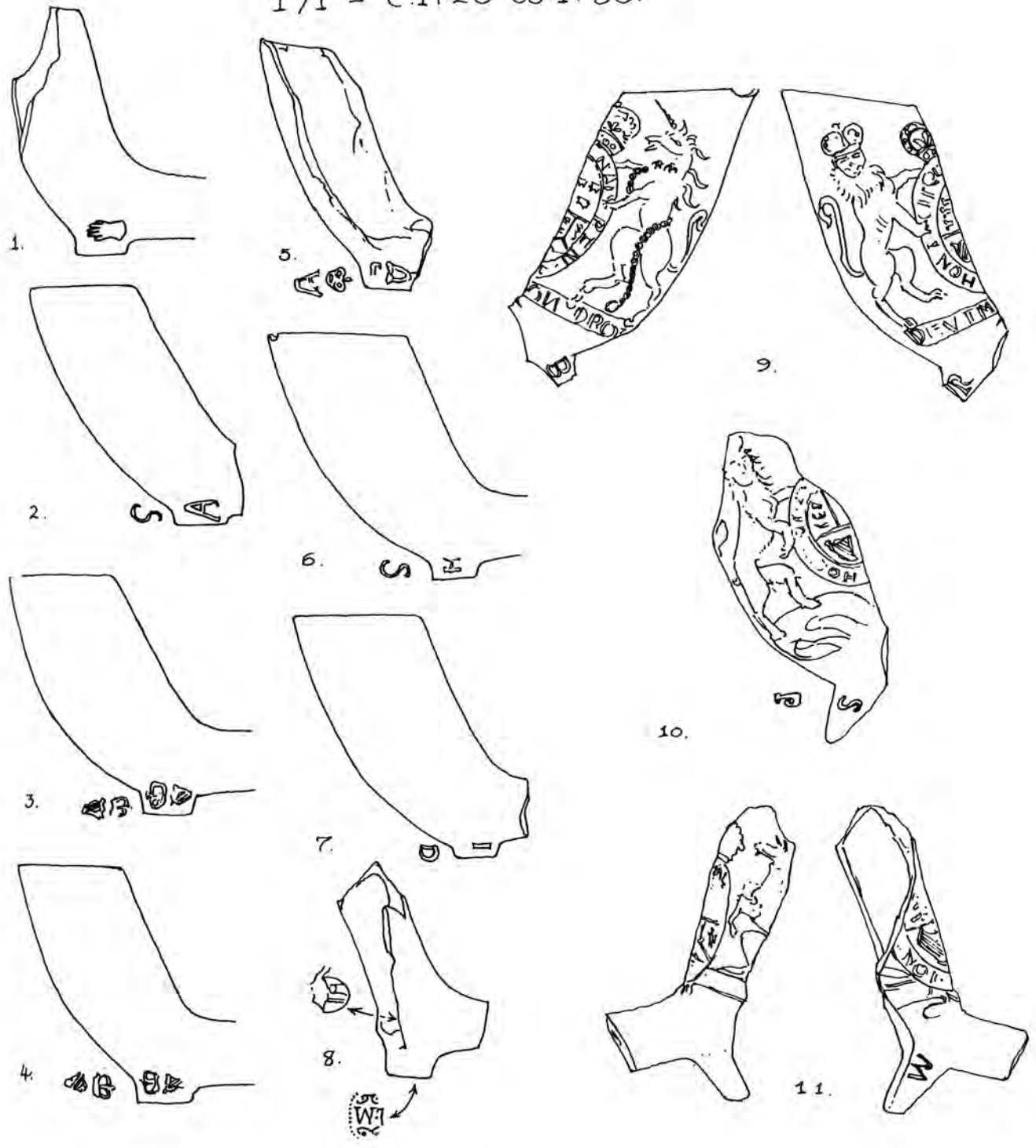

FIG. 10.

0 5cm

BLACKFRIARS to DOWGATE (N. BANK.)

R. THAMES.

1/1 - C.1720 to 1780.

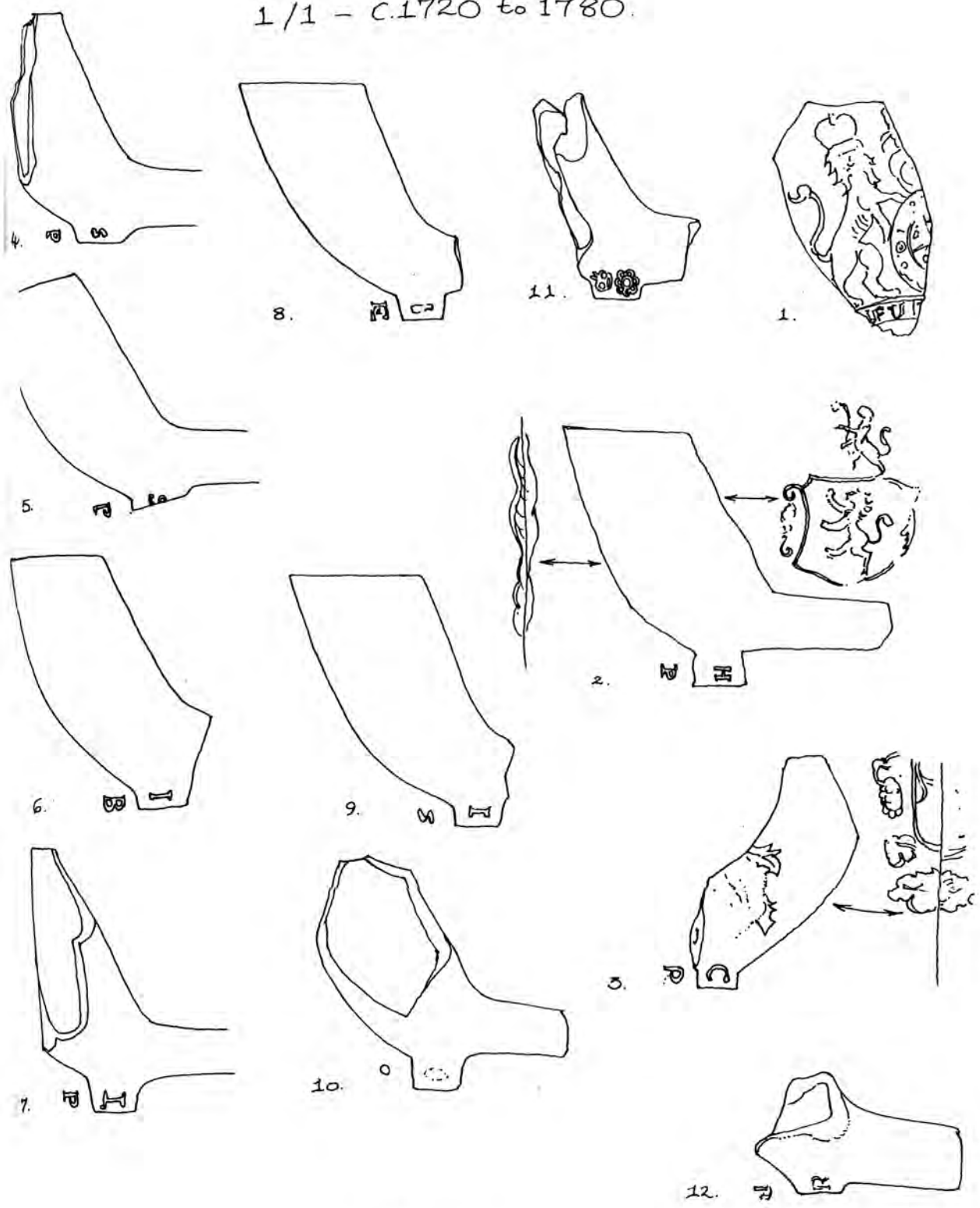

FIG. 11.



BLACKFRIARS to DOWGATE (N. BANK.)

R. THAMES.

1/1 - C.1720 to 1780.

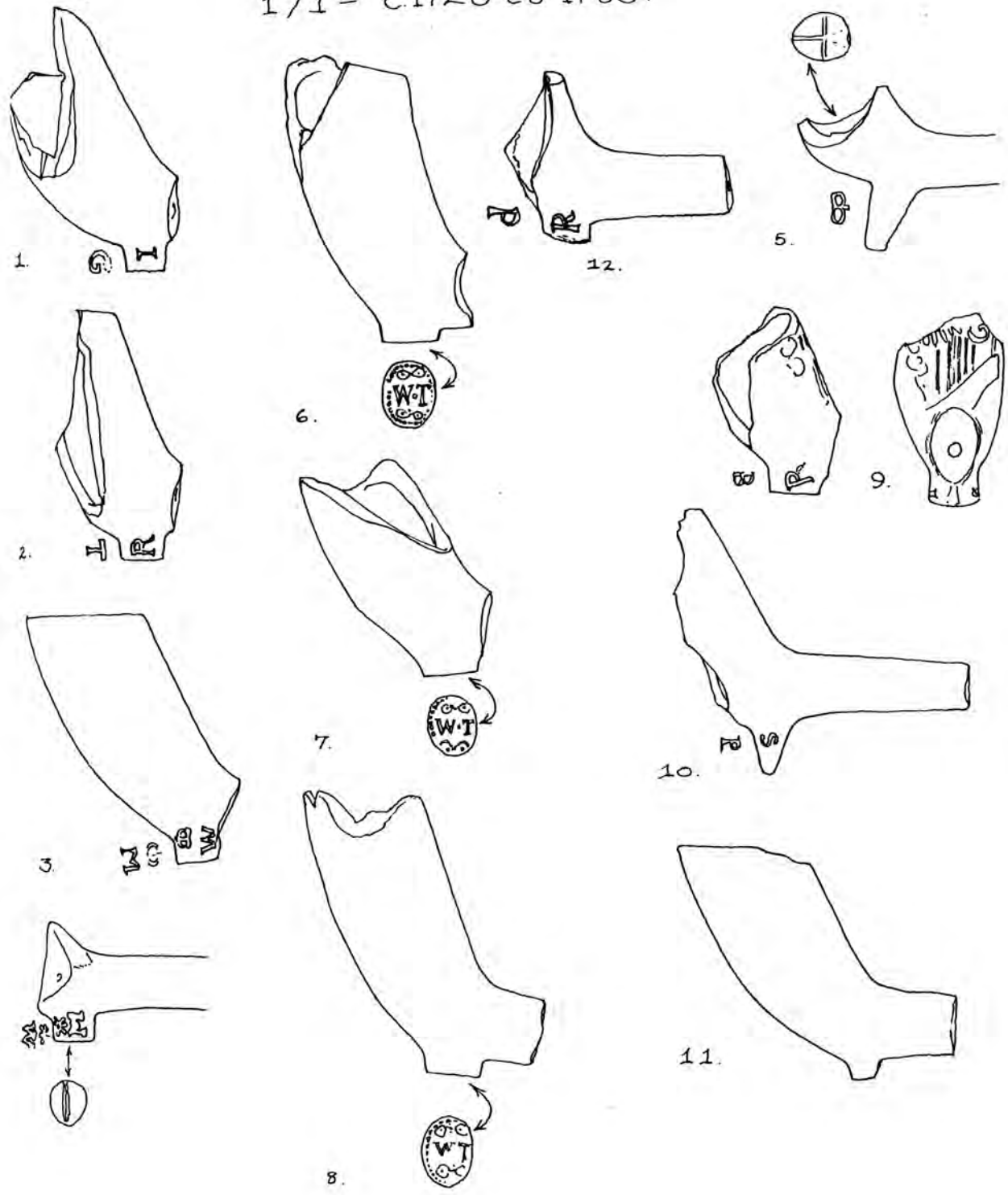

FIG 12.



BLACKFRIARS to DOWGATE. (N. BANK.)

R. THAMES.

1/1 - C1720. to 1780.

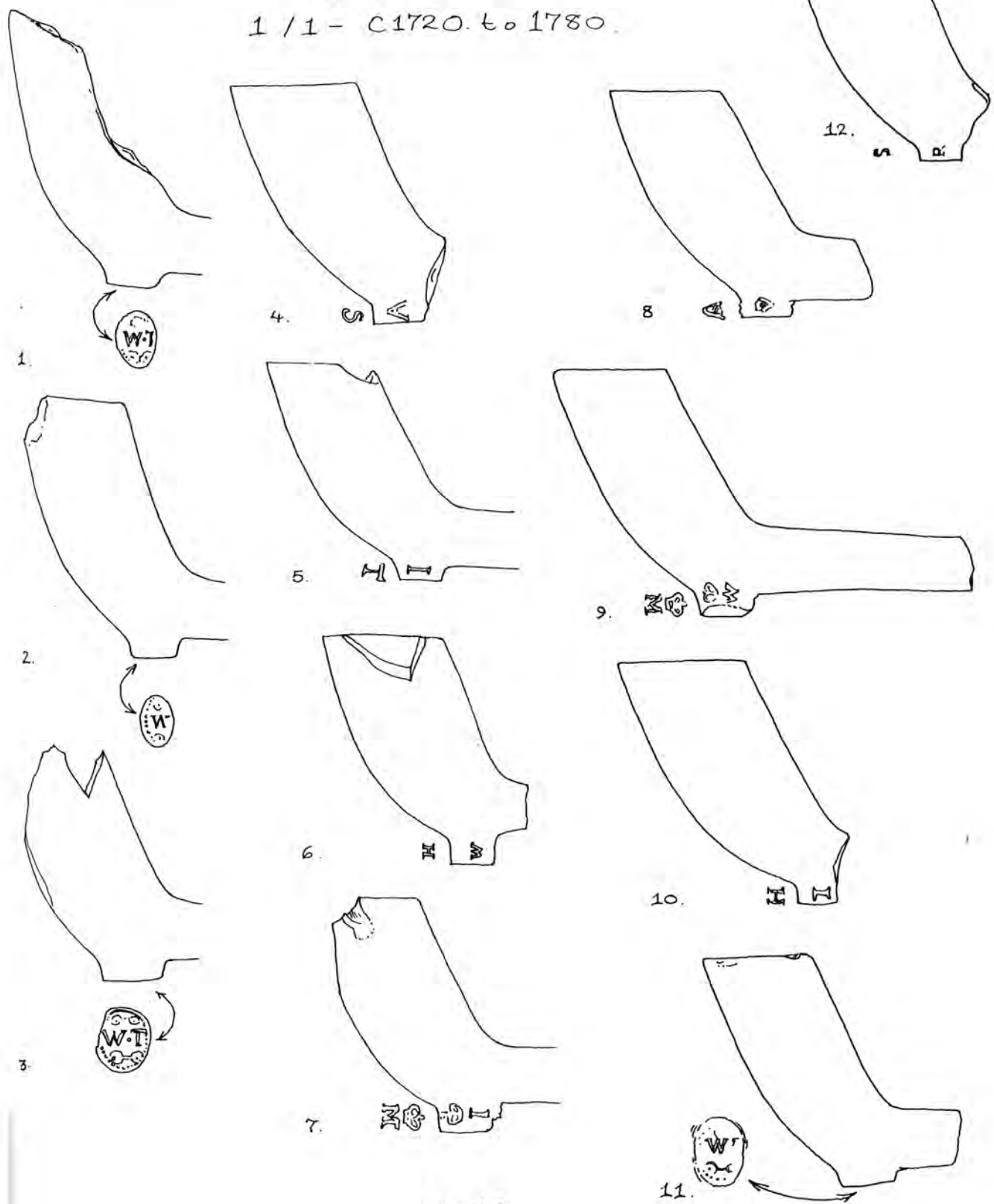

FIG. 13.



BLACKFRIARS to DOWGATE (N. BANK.)

R. THAMES.

1/1 - c.1720 to 1780.

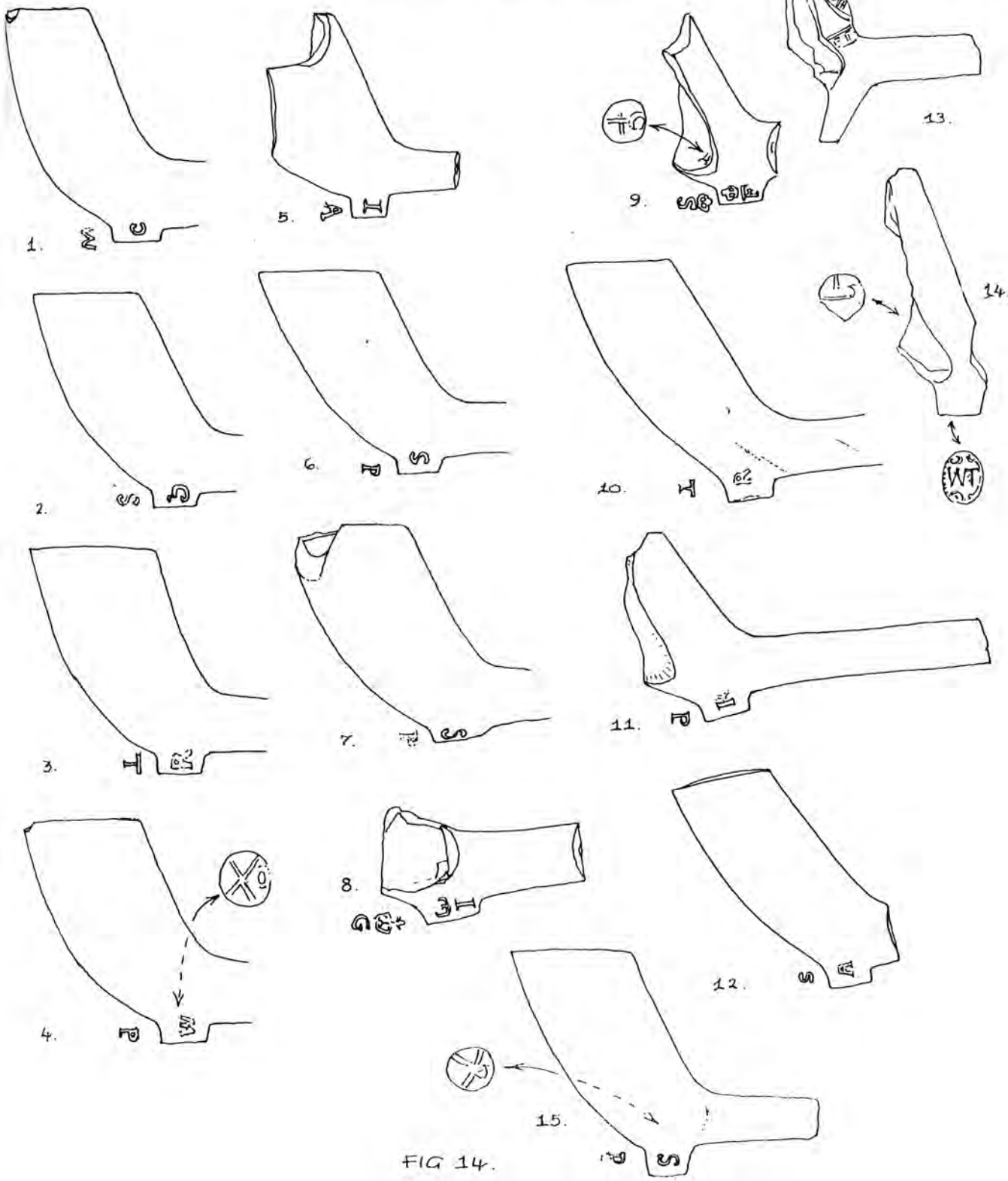

FIG 14.

BLACKFRIARS to DOWGATE. (N. BANK.)
R. THAMES.
1/1 - C.1720 to 1780.

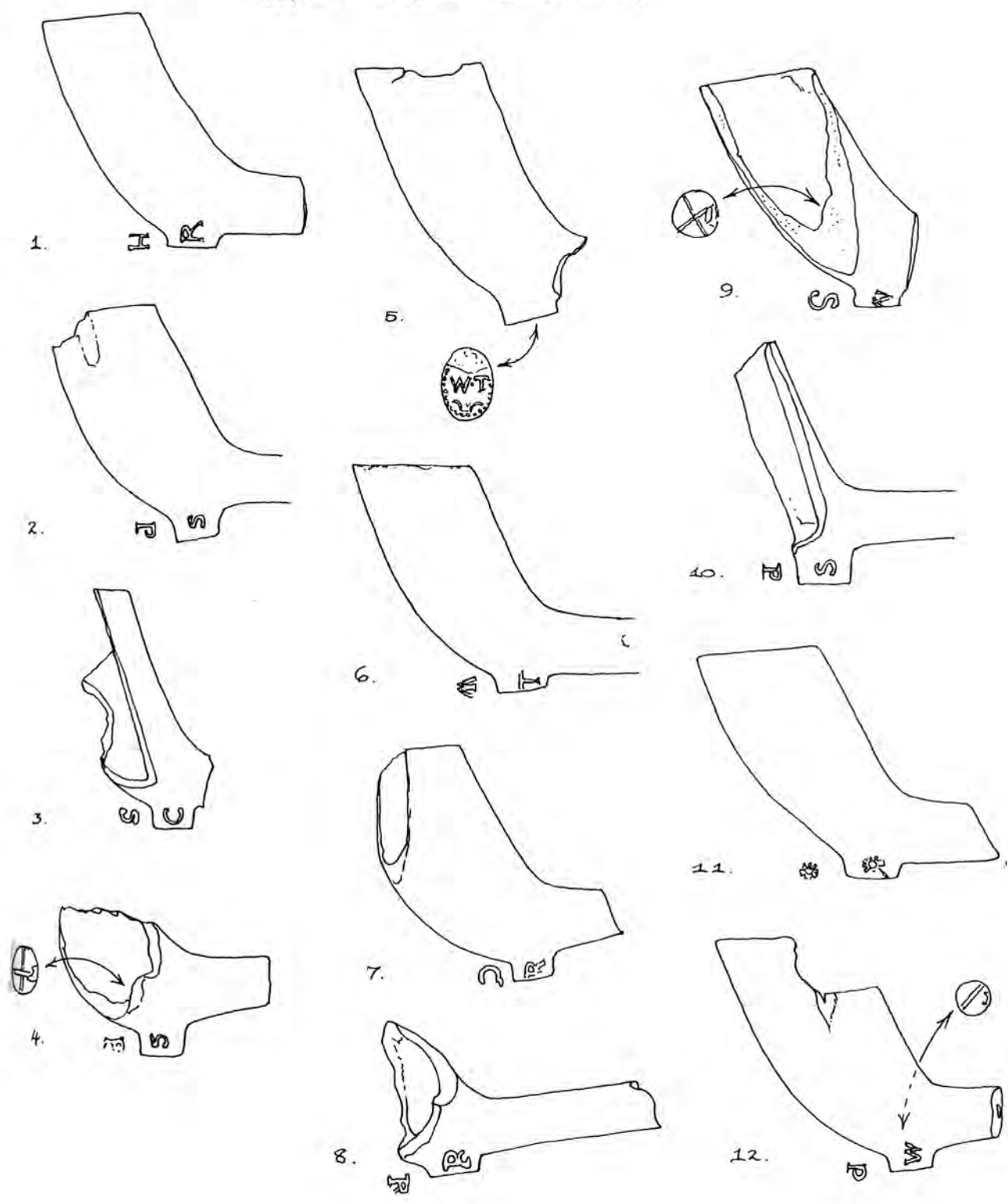

FIG. 15.



BLACKFRIARS to DOWGATE. (N BANK.)

R. THAMES.

1/1 - c.1720 to 1780.

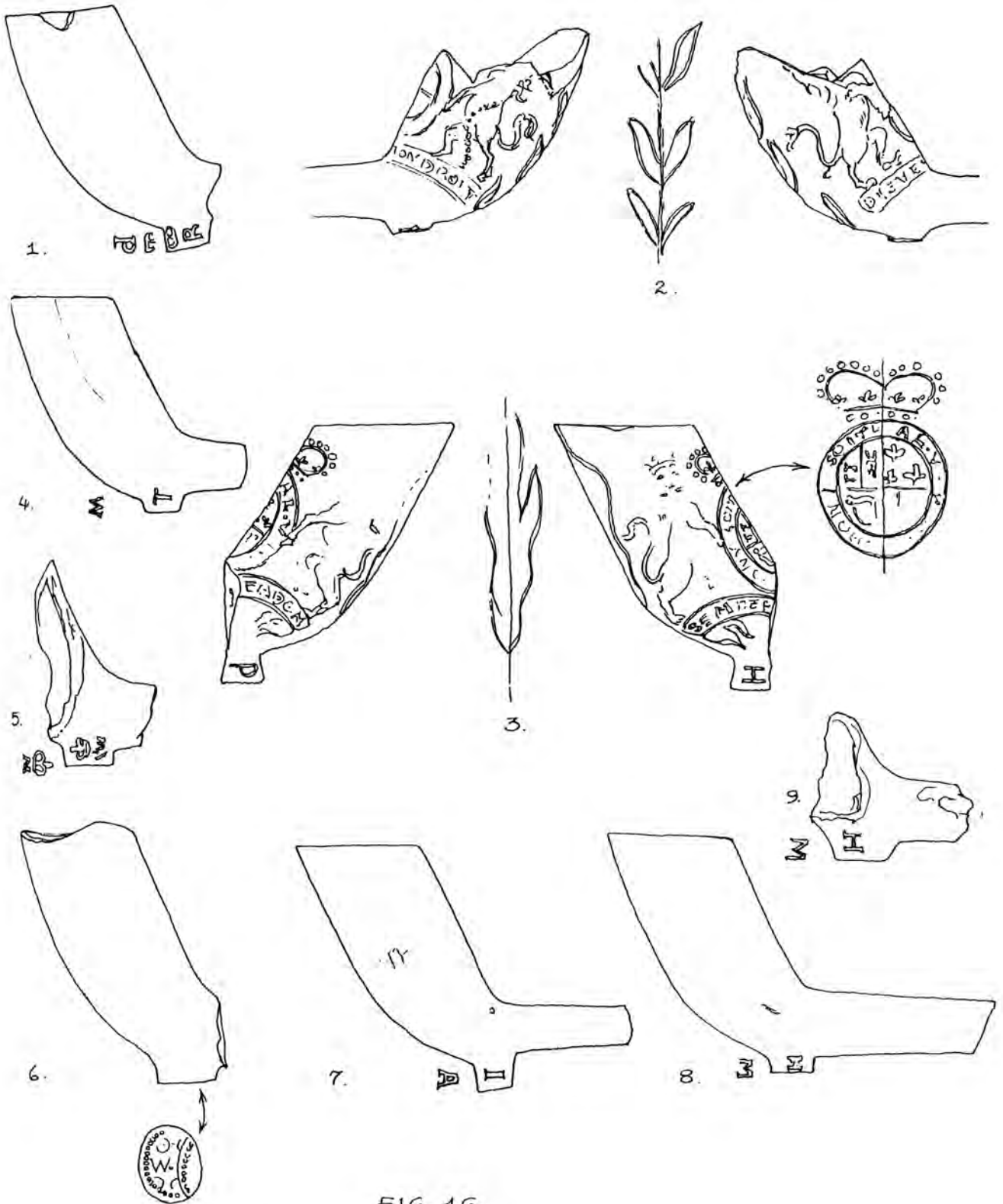

FIG. 16.

BLACKFRIARS to DOWGATE (N. BANK)

R. THAMES.

1/1 - C.1720 to 1780.

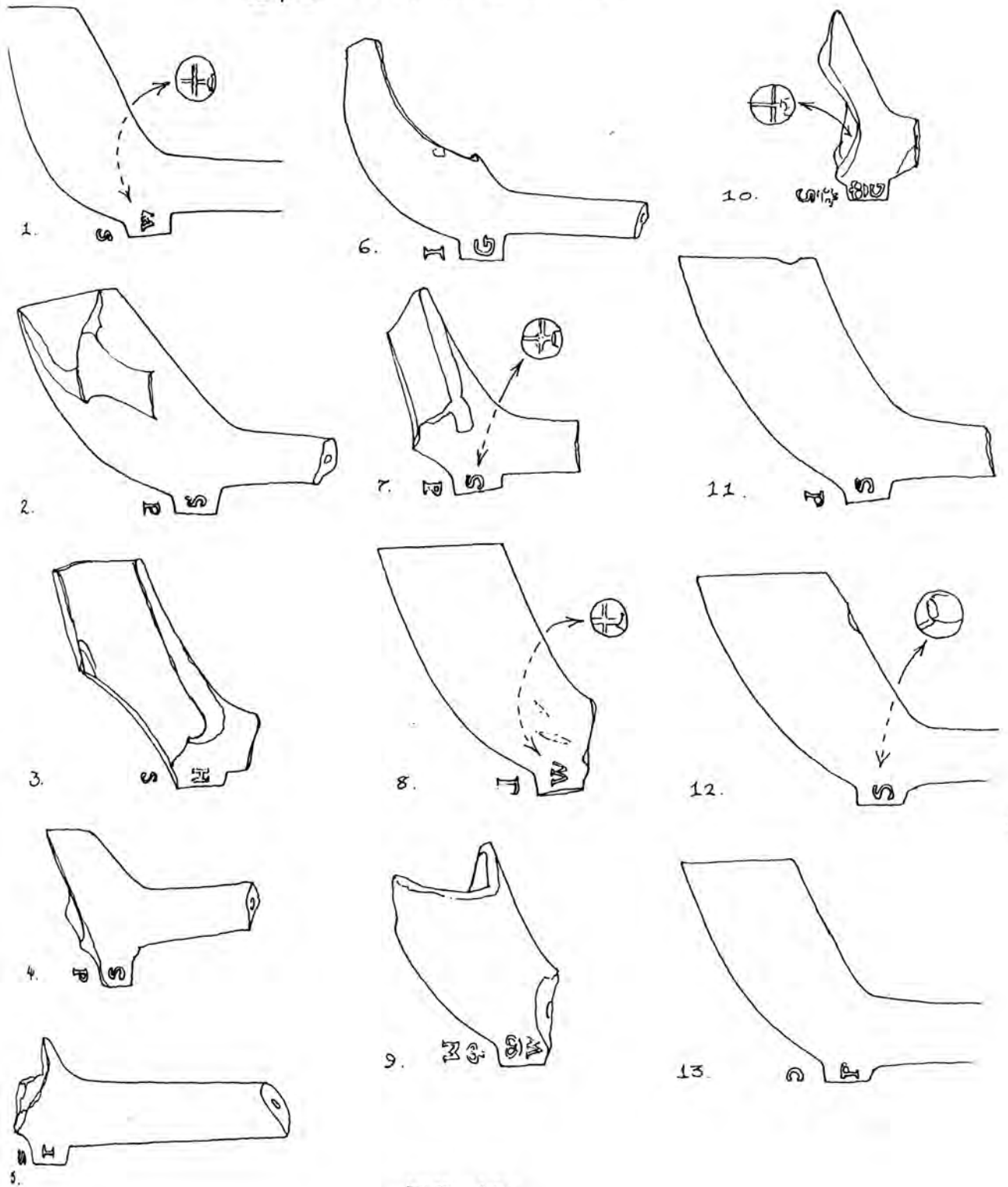

FIG. 17.

BLACKFRIARS to DOWGATE (N.BANK.)

R. THAMES.

1/1 - C. 1720 to 1780.

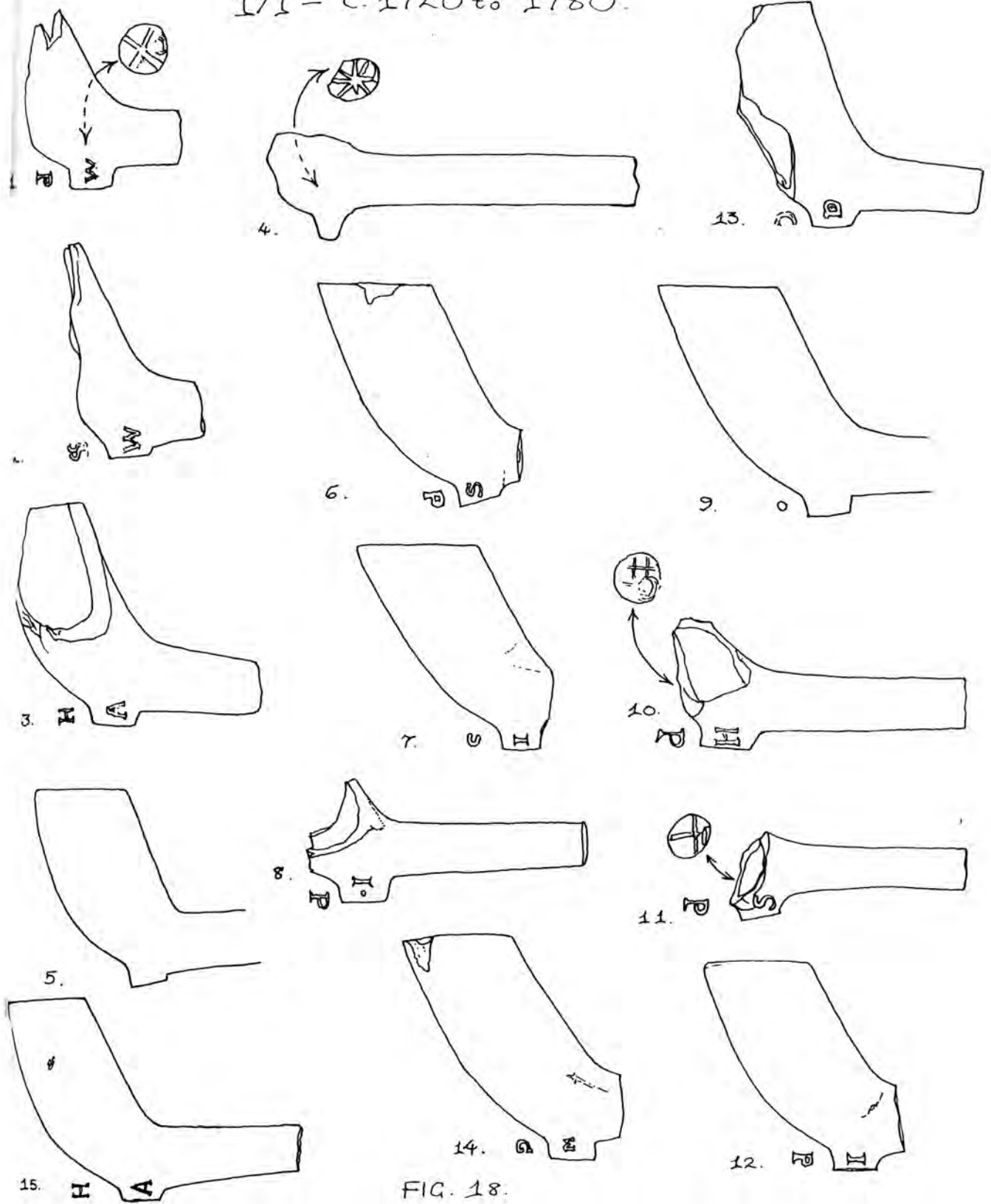

FIG. 18.

BLACKFRIARS to DOWGATE (N. BANK.)

R. THAMES.

1/1 - C. 1720 to 1780

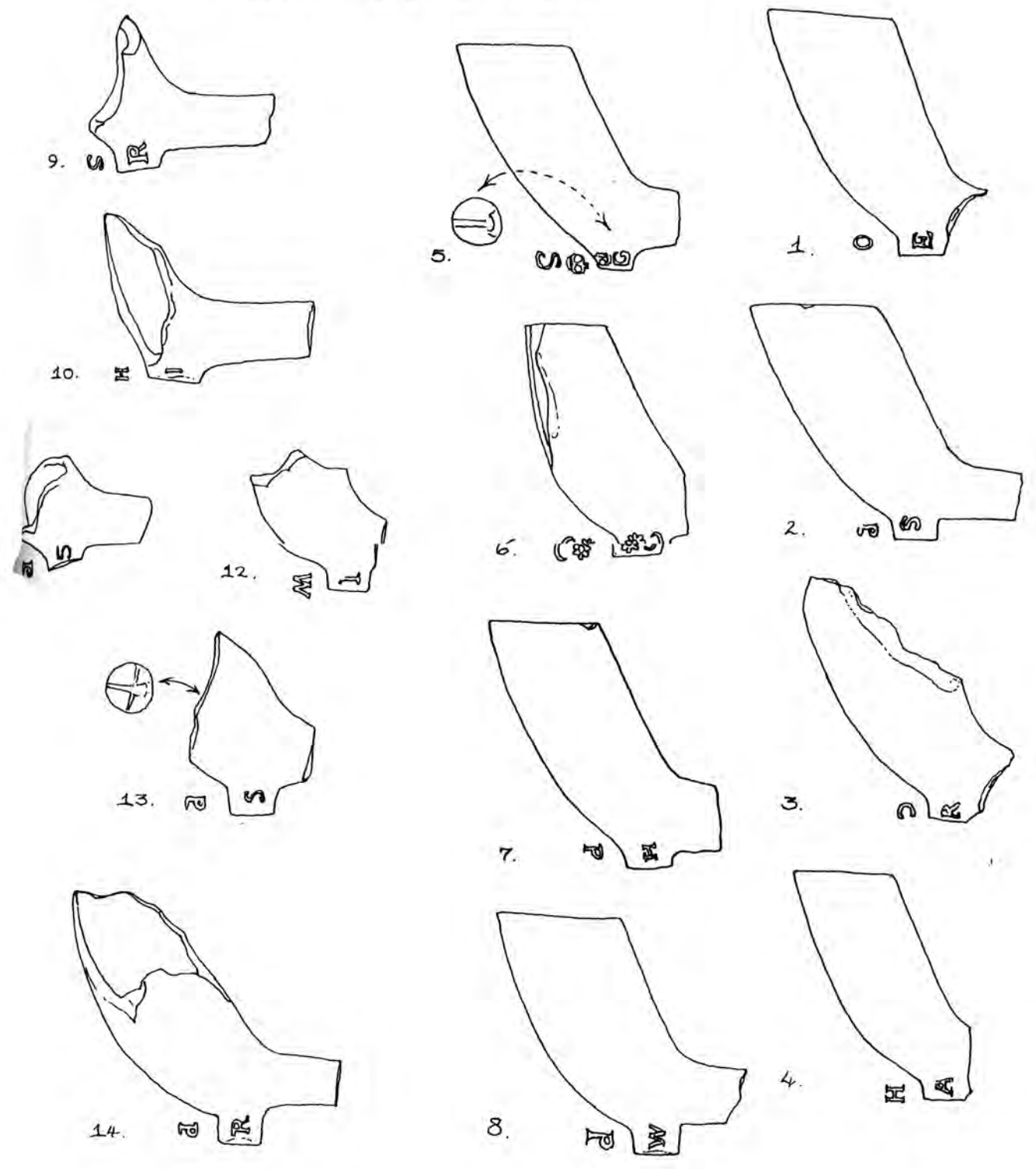

FIG. 19.



BLACKFRIARS to DOWGATE. (N. BANK.)

R. THAMES.

1/1 - C. 1720 to 1780.

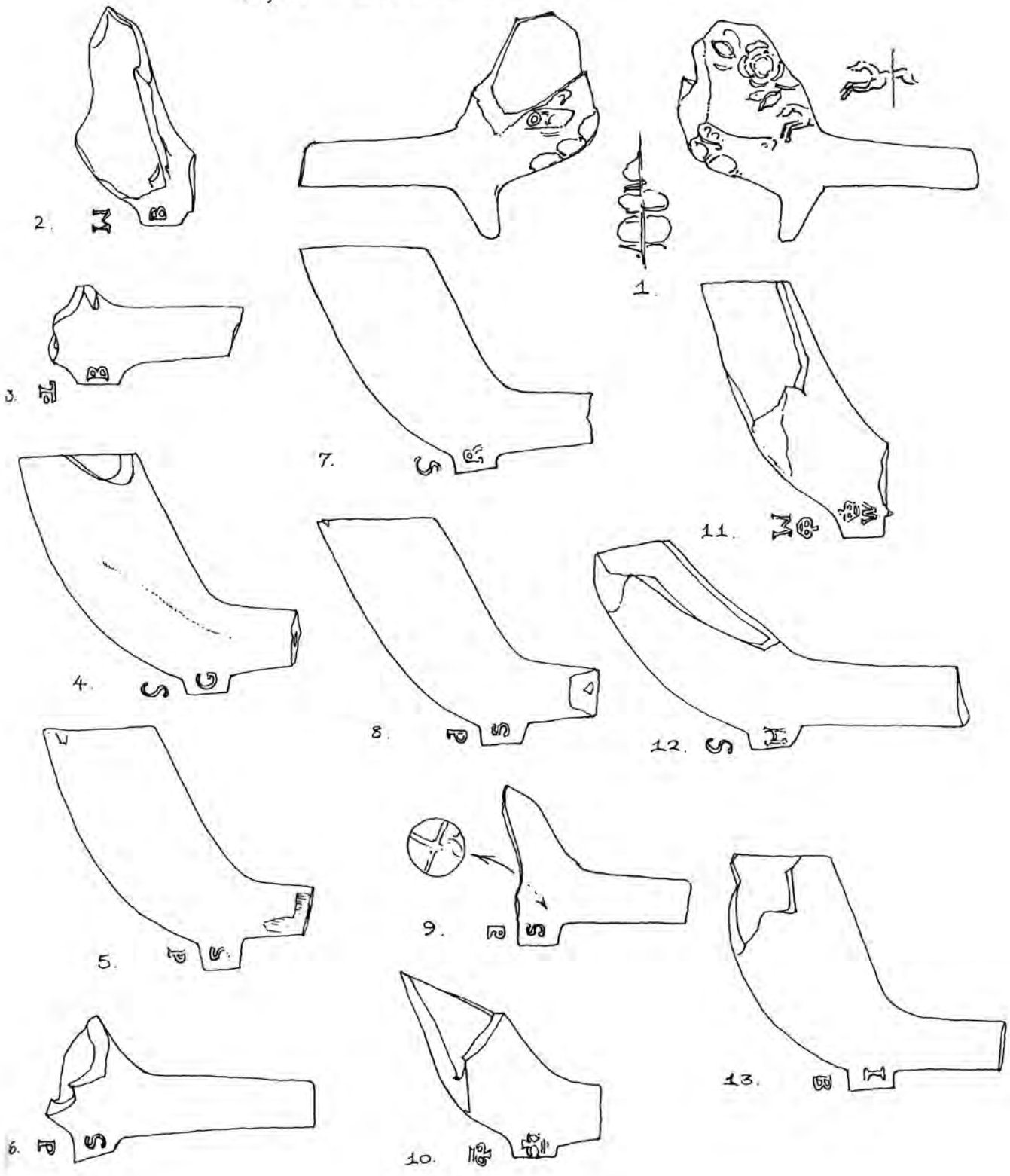

FIG. 20.



BLACKFRIARS TO DOWGATE (N. BANK.)

R. THAMES.

1/1 - C1720 to 1780.

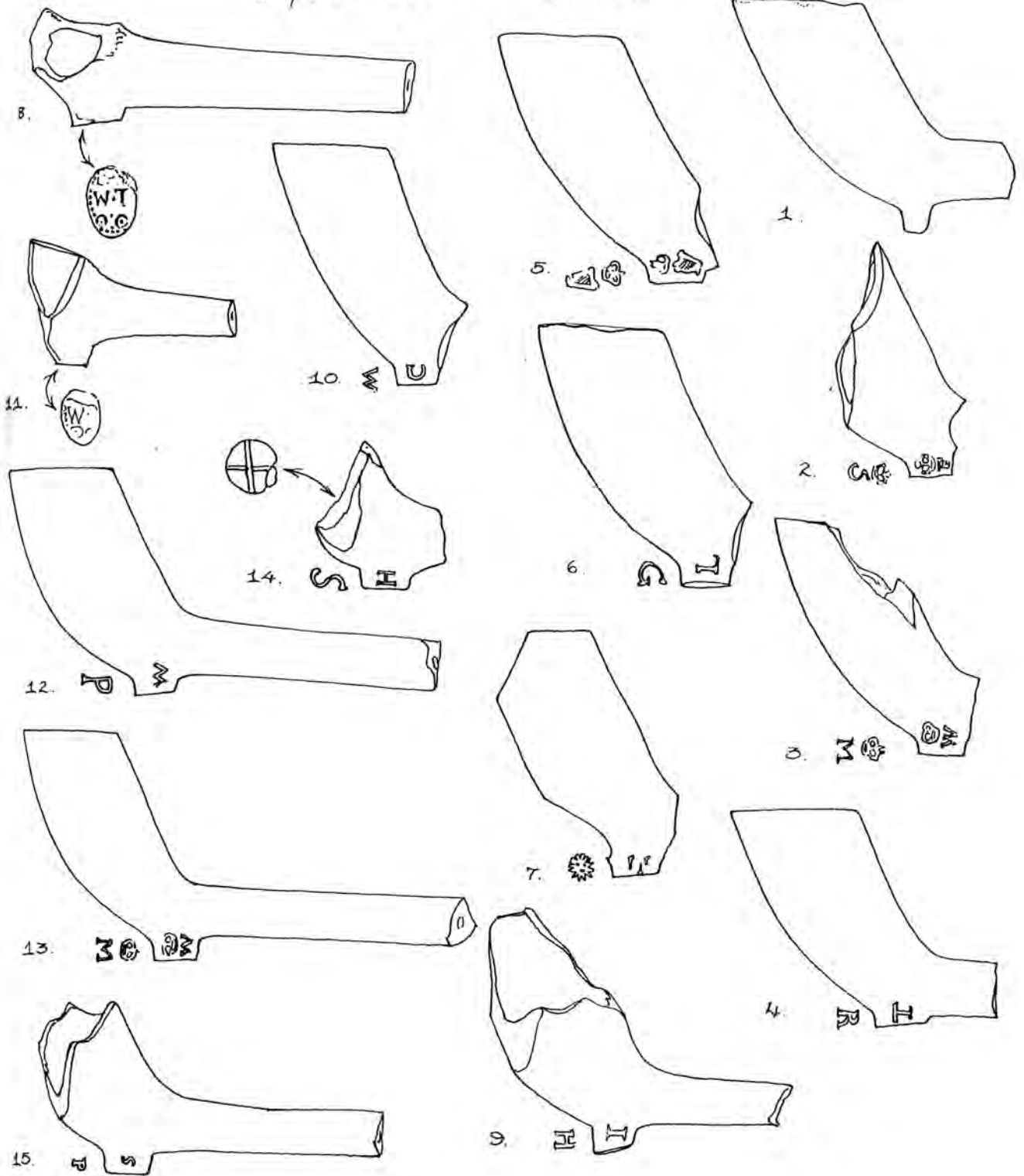

FIG. 21



BLACKFRIARS TO DOWGATE. (N. BANK.)

R. THAMES.

1/1 C. 1720-1780.

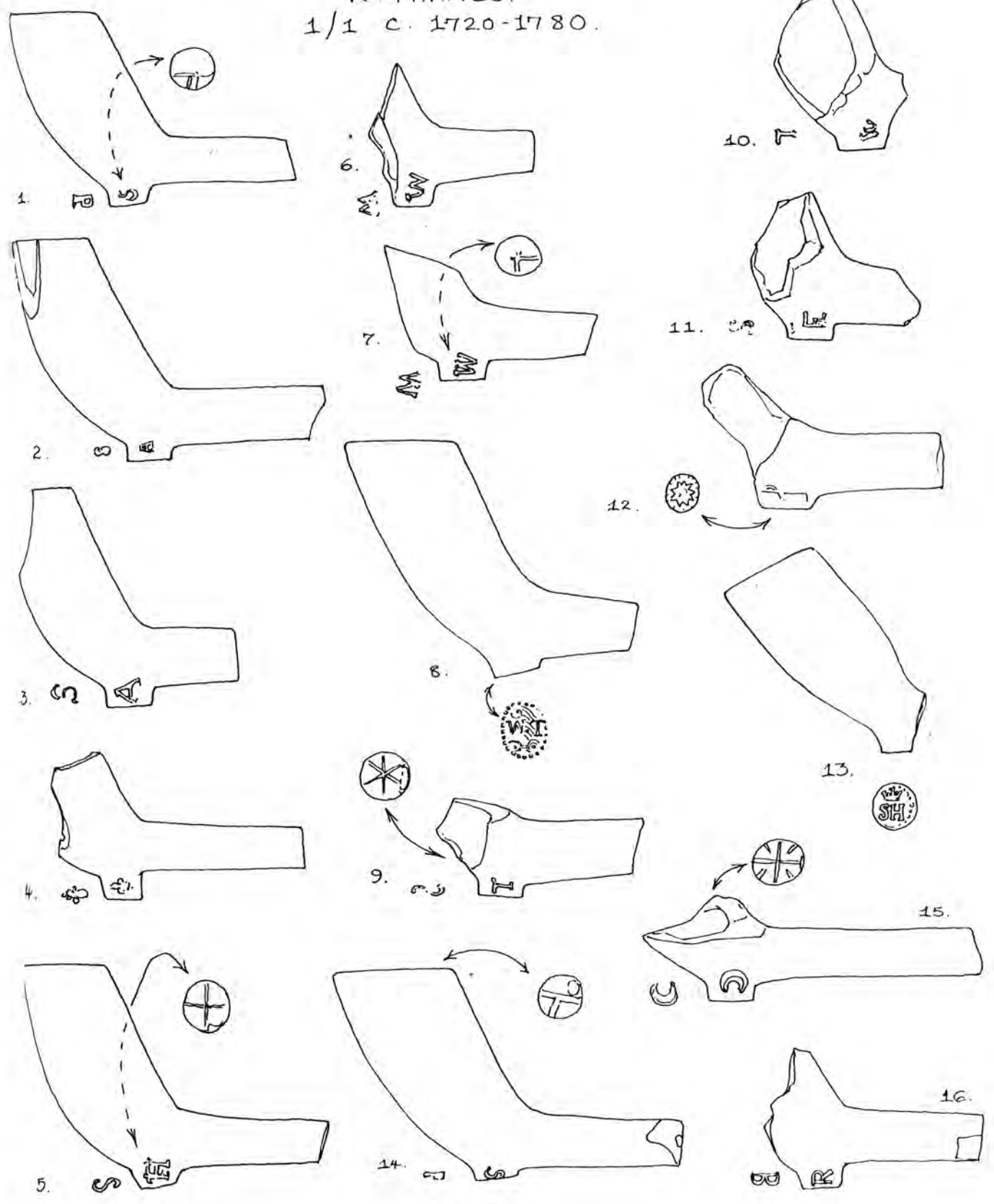

FIG. 22.



BLACKFRIARS to DOWGATE (N. BANK.)

R. THAMES.

1/1 C. 1720-1780.

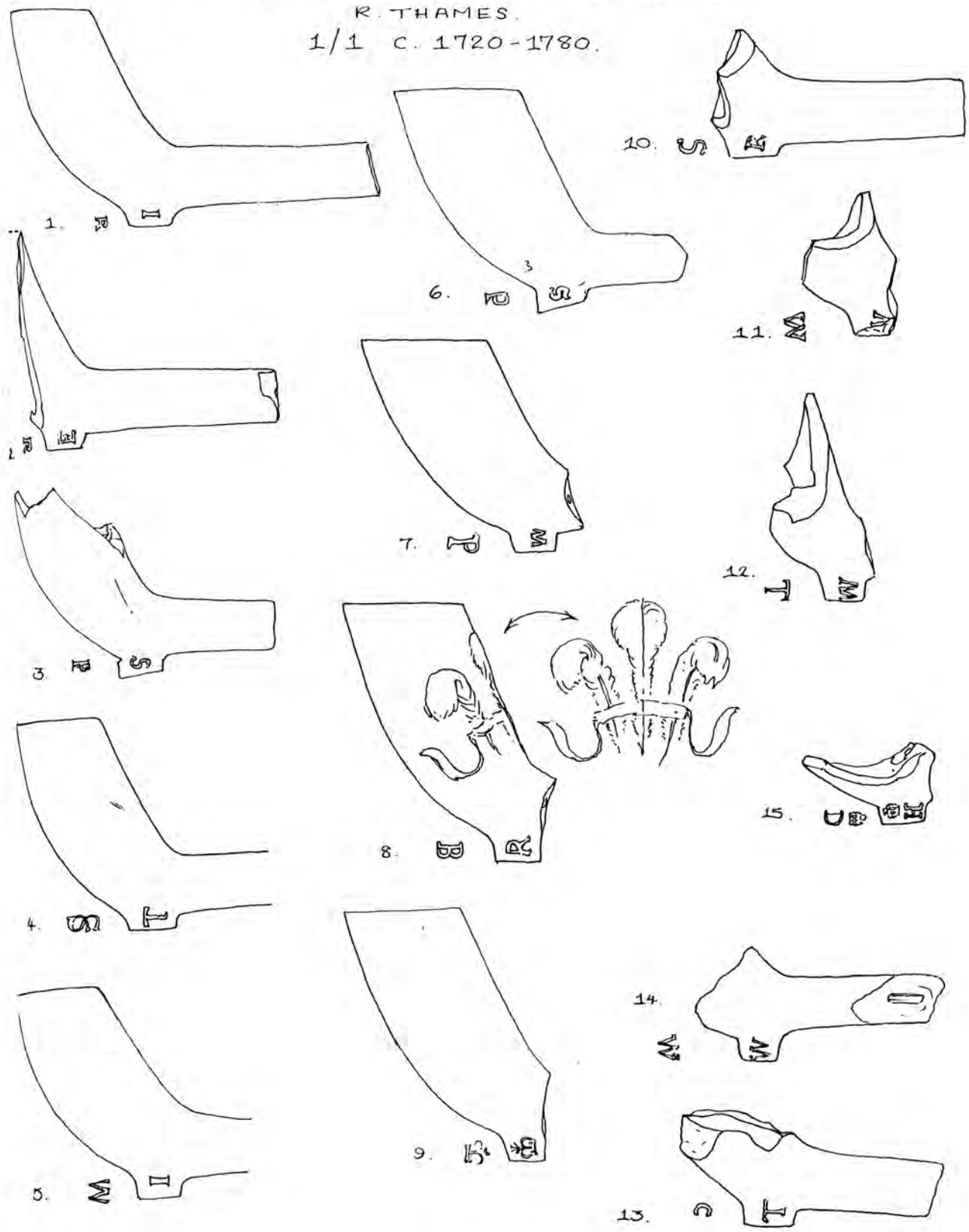

FIG 23.



BLACKFRIARS TO DOWGATE (N. BANK.)
R. THAMES.
1/1. C. 1720-1780.

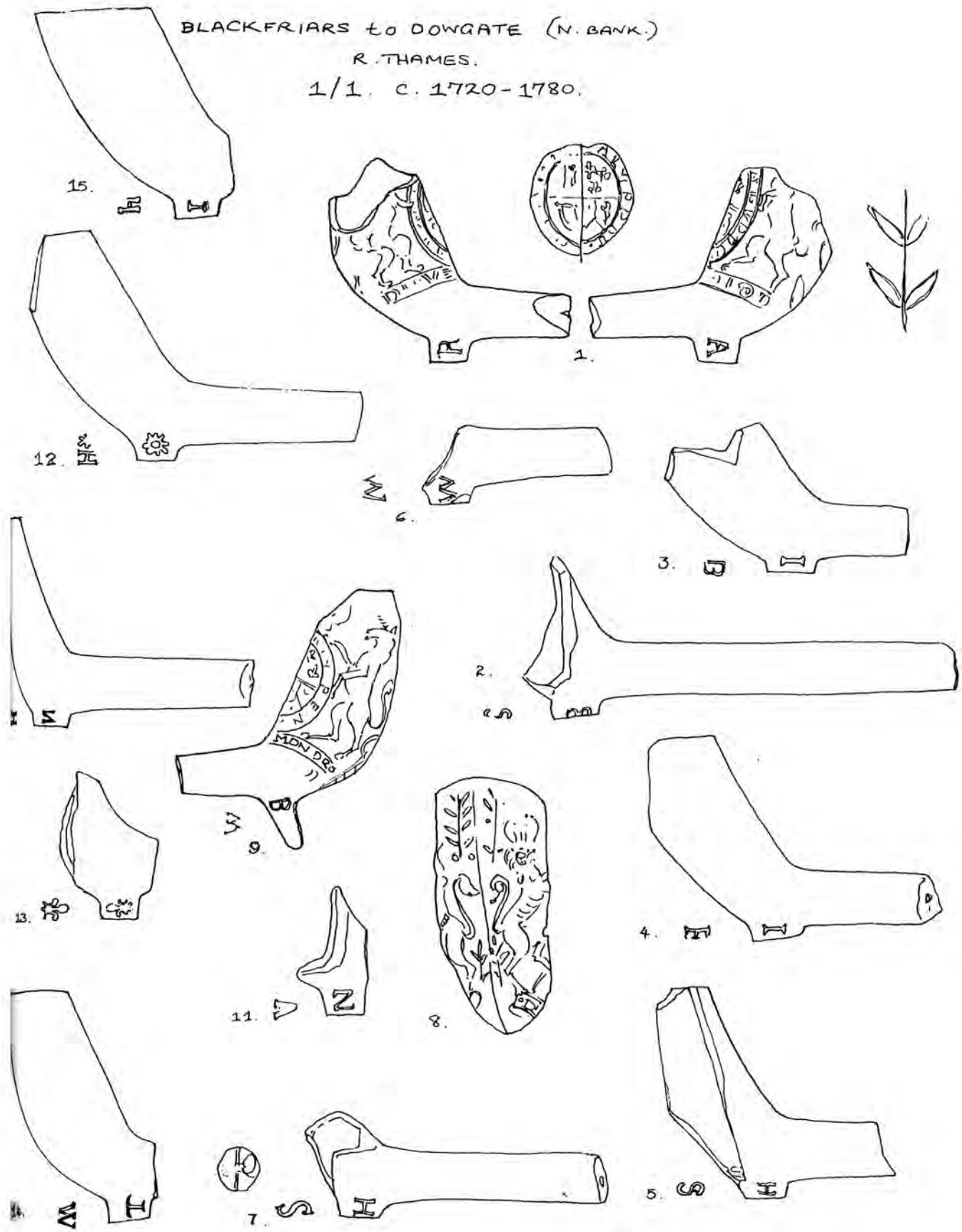

FIG. 24.

FIG. 1.

1. (16.11.82.) - QUEENHITHE.

C. 1730-50L. TYPE 25. S.B.D. 2.6 MM. GREY/WHITE CLAY. L.H.S. BASE - ROUND. 'W' AND PELLET BELOW CROWN. R.H.S. 'M' AND PELLET BELOW CROWN. POSSIBLY WILLIAM MAMBY. (2).

2. (16.10.82)

C. 1790-50L. TYPE 25. S.B.D. 2.6 MM MOTTLED WHITE/GREY CLAY, WITH IRON STAINING TOP OF STEM, R.H.S. OF BOWL + PURPLE STAINS. BASE - ROUND. L.H.S. 'W' BELOW CROWN. R.H.S. 'M' BELOW CROWN. STEM LENGTH FROM BACK OF BASE TO BREAK - 71.5 MM. AS ABOVE, POSSIBLY WILLIAM MAMBY. (2).

3. (3.12.82) PAULS WHARF.

C. 1750-70. L. TYPE 25. S.B.D. 2.4 MM. GREY/WHITE CLAY MOTTLED WITH IRON STAINS AND BLUE/GREY. THIN, OVAL BASE, SLIGHTLY SPLAYED, WITH THE INCUSE STAMP OF WILLIAM TAPPIN. (BLACKFRIARS 1763).

4 (21.11.82) PAULS WHARF

C. 1750-70. L. TYPE 25. S.B.D. 2.5 MM. LIGHT BUFF CLAY, MOTTLED GREY. BOWL BROKEN L.H.S. AND FRONT. LIP - THICK. BASE - WITH WILLIAM TAPPIN'S STAMP. THIS PIPE STYLE IS FROM THE 1720'S.

FIG. 1.

5. (6.10.82.)

C. 1750-70. L. TYPE 25. S.B.D. 2.3 MM. OFF-WHITE, GREYISH CLAY. THICK LIP, BROKEN FRONT, L.H.S., R.H.S. BASE, SLIGHTLY SPLAYED. STAMP OF WILLIAM TAPPIN.

6. (3.10.82.)

C. 1750-70 L. TYPE 25. S.B.D. 2.1 MM. GOOD QUALITY W. TAPPIN BOWL. SMOOTH, POLISHED SURFACE. THIN LIP TO BOWL, WIDE CAVITY, CHIPPED R.H.S. LARGE, CYLINDRICAL BASE WITH CLEAR, CENTRAL STAMP.

7. (3.12.82.) BROOK'S WHARF.

C. 1720-50. L. TYPE 25. S.B.D. 2.5 MM. CREAMY WHITE CLAY. VERY THICK LIP. 'R' 'B' BACK OF BOWL IN RELIEF. 'A' 'H' ON SIDES OF SPUR. SIMILAR TO BAR 14, P. 87 NO 4. OSWALD: 'A/H OCCURS ON PIPES FROM LONDON C. 1720-50 MAY BE ABLE HORTON, 1717, OR ANTHONY HAYNES, 1722. RB COULD BE RICHARD BRYANT, 1733-40, OR ROBERT BALDWIN, 1749.

8. (3.12.82.) PAUL'S WHARF.

C. 1760-80. L. TYPE 25. S.B.D. 1.75 MM. GREYISH CLAY. BOWL FRONT BROKEN. SMOKE STAINS INSIDE TOP OF CAVITY. LONG OVAL SPUR, INITIALED W/T. CERTAINLY NOT THE STYLE, AND TOO LATE, IN ALL PROBABILITY FOR W. TAPPIN.

FIG. 1.

9. (10. 10. 82.)

C. 1750-70. L. TYPE 25. S.B.D. 2 MM. WHITE CREAMY CLAY. MEDIUM BOWL THICKNESS.

IRON STAINS L.H.S. ROUND BASE LETTERED W/W. POSSIBLY WILLIAM WILDER 1717-63.

THE BOWL CAVITY HAS AN INTERNAL CROSS. ON PIPES, IN THE MAIN, FROM 1720-60 (OSWALD.)

10. (16. 10. 82.)

C. 1770-80. L. TYPE 25. S. B. D. 2 MM. BACK/L.H.S., BOWL REMAINING. IRON STAINS.

LIP-THIN. ROUND SPUR WITH 'B' SHAPED CROWNS. STEM-THIN.

11. (26. 11. 82.) PAUL'S WHARF.

C. 1740-60. L. TYPE 25. S. B. D. 2.5 MM. OFF-WHITE CLAY. BOWL BROKEN. MEDIUM THICK.

THICKISH STEM. IRON STAIN R.H.S. OF STEM. OVAL SPUR, LETTERED C/W.

12. (14. 11. 85.)

C. 1750-70. L. TYPE 25. S. B. D. 2 MM. GREYISH FABRIC; IRON-STAIN L.H.S.; POLISHED SURFACE;

INTERNAL CAVITY CROSS; WT INCUSE MARK ON BASE, WILLIAM TAPPIN, FI. BLACKFRIARS 1763.

FIG. 2

1. (3.1.83.) PAULS WHARF.

C. 1750-70. L. TYPE 25. S.B.D. 2.3 MM. OFF-WHITE/GREY CLAY WITH MOTTLES OF BLUE/GREY. THICK, FLAT LIP. WILLIAM TAPPIN'S STAMP ON BASE. ACCORDING TO OSWALD, BAR 97, TAPPIN WAS WORKING AT BLACKFRIARS, 1763, BUT HIS PIPES AND MARK RELATED TO THE 1720'S.

2. (3.12.82.) PAULS WHARF.

C. 1750-70. L. TYPE 25. S.B.D. 2.3 MM. BOWL AND STEM FRAGMENT WITH WILLIAM TAPPIN'S STAMP ON OVAL BASE.

3. (17.12.82.) QUEENHITHE.

C. 1750-70 L. TYPE 25. S.B.D. 2.3 MM. WHITE CLAY WITH IRON STAINS. WILLIAM TAPPIN'S STAMP ON OVAL BASE.

4. (3.12.83.) PAULS WHARF.

C. 1750-70. L. TYPE 25. S.B.D. 2.3 MM. WHITE/CREAM CLAY. W. TAPPIN'S STAMP ON ROUND/OVAL BASE.

5. (3.12.83.) NEAR SOUTHWARK BRIDGE.

C. 1730-60. L. TYPE 25. S.B.D. 2 MM. WHITE/CREAM CLAY. R.H.S. BOWL BROKEN. 'I?' 'G' ON SPUR WITH CROWNS ABOVE.

FIG. 2.

6. (3.12.82) - QUEENHITHE.

C. 1730-60. L. TYPE 25. S.B.D. 2.1 MM. WHITE-CREAMY CLAY. IRON STAINING FRONT,
R.H.S. OF BOWL. ROUND BASE. R/S ON SPUR.

7. (20.9.82.)

C. 1730-60. L. TYPE 25. S.B.D. 2.3 MM. WHITE/BUFF, SHINY CLAY. ROUND SPUR
WITH 'I'/'W'.

8. (3.1.83) NEAR SOUTHWARK BRIDGE.

C. 1730-60. L. TYPE 25. S.B.D. 2.4 MM. WHITE/CREAM CLAY, L.H.S. IRON STAINS.
HP-THICK. OVAL/ROUND SPUR. 'I'/'A'.

9. (16.11.82.)

C. 1750-70. L. TYPE 25. S.B.D. 2.3 MM. MOTTLED SURFACE - BLUE/GREY. THIN-MEDIUM
THICKNESS. SLANTING FORWARD, OVAL SPUR, LETTERED R/S.

10. (3.12.82.) QUEENHITHE.

C. 1740-60. L. TYPE 25. S.B.D. 2 MM. GREYISH CLAY. POLISHED. BROWNISH RED/BLUE-GREY
PATCHES L.H.S. ROUND SPUR, INITIALED W/P. TRACE OF PLUNGER MARK ON INNER BASE,
L.H.S. BORE HOLE EXIT.

FIG. 2.

11. (3.12.82) PAUL'S WHARF.

C. 1750-70. L. TYPE 25. S.B.D. 2 MM. GREYISH CLAY, MOTTLED BROWN AND RUST L.H.S.

THICK LIP - WIDE MOUTH. OVAL SPUR, LETTERED L/B.

12. (3.12.82.)

C. 1750-70. L. TYPE 25. S.B.D. 2 MM. GREYISH CLAY. BOWL FRONT THIN; BOWL BACK THICK.

SILATED OVAL SPUR, LETTERED I/W.

13. (1985)

C. 1750-70. L. TYPE 25. S.B.D. 2.2 MM. SMOKED, MEDIUM-THIN BOWL; OVAL SPUR; M/S MARKER.

UNCERTAIN.

FIG. 3.

1. (17.12.82.) BROOK'S WHARF.

C. 1750-70. L. TYPE 25. S.B.D. 2.3 MM. WHITE CLAY WITH IRON STAINING.
CYLINDRICAL BASE. WILLIAM TAPPIN'S STAMP.

2. (10.10.82.)

C. 1750-70. L. TYPE 25. S.B.D. 2 MM. CREAMY WHITE CLAY, SHINY. INSIDE
OF BOWL BASE BLACKENED. OVAL, SPLAYED BASE. W. TAPPIN'S STAMP. STEM, THIN.

3. (10.10.82.)

C. 1750-70 L. TYPE 25. S.B.D. 2.5 MM. SMOOTH, SHINY, CREAMY WHITE CLAY.
OVAL BASE. CLEAR, W. TAPPIN'S STAMP.

4. (3.12.82.) - QUEENHITHE.

C. 1750-70. L. TYPE 25. S.B.D. 2.3 MM. GREY-WHITE CLAY. BROKEN BOWL.
W. TAPPIN'S STAMP ON OVAL BASE. IRON STAINS L.H.S. OF BOWL.

5. (21.11.82.) - QUEENHITHE.

C. 1730-60. L. TYPE 25. S.B.D. 2.5 MM. GREY/WHITE, SHINY CLAY. 'I'/'S' ON
ROUND SPUR.



FIG 3.

6. (6.10.82.)

C. 1750. L. TYPE 25. S.B.D. 2.30. WHITISH CLAY. LIP CHIPPED. OVAL BASE.
B/T ON SPUR. POSSIBLY BENJAMIN TURNER, 1749 WESTMINSTER POLLS.

7. (3.10.82.)

C. 1730-60. L. TYPE 25. S.B.D. 2.2 MM. WHITE, SMOOTH CLAY. SMALL, ROUND
SPUR WITH THE LETTERS R/C.

8. (3.12.82) PAULS WHARF.

C. 1730-60 L. TYPE 25. S.B.D. 2.4 MM. WHITE CLAY. CHIPPED LIP, BACK
AND FRONT. SMALL ROUND SPUR WITH THE LETTERS I/A. THE 'A' BEING
MUCH LARGER THAN THE 'I'.

9. (10. 10. 82.)

C. 1750-70. L. TYPE 25 S.B.D. 2 MM. LARGE GREYISH, FAWN BOWL. OVAL SPUR.
OBSCURE CROWN MARKS AND LETTERED ?/S .

10. (21. 11. 82.) PAUL'S WHARF.

C. 1750-70. L. TYPE 25. S.B.D. 2 MM. FRONT OF BOWL BROKEN. THIN LIP. OVAL SPUR,
INITIALED H/S.

FIG 3.

11. (10.10.82.)

C. 1740-70. L. TYPE 25. S.B.D. 2.1 MM. CURIOUS STYLISED TOBACCO PLANT, POSSIBLY, DEPICTED ON THIS BOWL/BASE FRAGMENT. ROUND SPUR.

12. (21.11.82.) QUEENHITHE.

C. 1740-60. L. TYPE 25. S.B.D. 2 MM. THIN/MEDIUM THICKNESS. BACK OF BOWL BROKEN. SMALL OVAL/ROUND SPUR CLEARLY LETTERED R/C. INTERNAL CAVITY CROSS IN RELIEF.

13. (27.8.84.) QUEENHITHE/BLACKFRIARS.

C. 1750-70. L. TYPE 25. S.B.D. 2 MM. SMOKED, FAIRLY UPRIGHT, GREYISH BOWL FRAGMENT. 'CRYSTALLINE' TYPE MARKINGS IN CAVITY BASE, 'B' TYPE CROWNS ON SIDES OF SQUARISH BASE.

Cf. FIG. 1, NO. 10.

14. (12.9.84.)

C. 1730-50. L. TYPE 25. S.B.D. 2.1 MM. ROUND BASE AND STEM BREAK — CENTRAL BORE. SMALL I/A ON SIDES. PERHAPS JAMES ALLEN 1716 F; JONATHAN ADAMS, 1725 F.

15. (12.9.84.)

C. 1750-70. L. TYPE 25. S.B.D. 2.1 MM. LIGHT GREYISH STEM PIECE; OVAL STEM BREAK; OBLIQUE, FORWARD SLOPING SPUR — OVAL WITH E/G ON SIDES. SERIES OF 'E' OBSCURED. MAKER, UNCERTAIN.

16. (28.9.84.)

FIG. 3.

C. 1730-50. K. TYPE 25. S.B.P. 2.2 MM. THICK, GREY, NARROW S/P BOWL; DOWNWARD SLOPING BASE - CHIPPED; GREY OAPPLS FRONT/L.H.S.



FIG. 4.

1. (20.9.82).

C. 1730-60. L. TYPE 25. S.B.D. 2.1. WHITISH CLAY. LIP CHIPPED FRONT, R.H.S.
SMOKE-STAINS INSIDE BOWL CAVITY. ROUND SPUR WITH FLASH. INITIALED - W/B.

2. (16.11.82)

C. 1730-60. L. TYPE 25. S.B.D. 2 MM. WHITISH, POLISHED CLAY. SMOKE-STAINS
INSIDE CAVITY. MIS-SHAPED ROUND BASE. H/? LETTERED ON SPUR.

3. (13.10.82)

C. 1730-60. L. TYPE 25. S.B.D. 2.2 MM. OFF-WHITE, BURNISHED CLAY.
LIP CHIPPED FRONT, L.H.S. R/T ON ROUND SPUR.

4. (3.12.82) - QUEENHITHE.

C. 1730-60 L. TYPE 25. S.B.D. 2.2 MM. WHITISH CLAY - WEATHERED.
SMOKE AND IRON STAINS INSIDE CAVITY. LONG, OVAL SPUR - LETTERED C/W.

5. (6.10.82).

C. 1740-70 L. TYPE 25. S.B.D. 2.5 MM. WHITE/GREY SHINY CLAY.
ROSETTES ON ROUND SPUR.

6. (20.9.82).

C. 1740-70 L. TYPE 25. S.B.D. 2.5 MM. WHITISH CLAY. ROSETTES ON ROUND SPUR
INTERNAL STAR PATTERN - BASE OF CAVITY.

FIG 4.

7. (6.10.82.)

C. 1740-70. L. TYPE 25. S.B.D. 2.3. SMOOTH WHITISH CLAY, IRON STAINING L.H.S. AND FRONT ON BOWL. WIDE MOUTH, THICK LIP. SMOKE STAINED INSIDE CAVITY. ROUND FOOT, DROPPING FORWARD AND SIDE WAYS. ROSETTES EACH SIDE OF BASE.

8. (16.11.82) - QUEENHITHE.

C. 1740-70. L. TYPE 25. S.B.D. 2.5 MM. OFF-WHITE CLAY. ROSETTES EACH SIDE OF OVAL/ROUND BASE.

9. (3.12.82) PAUL'S WHARF.

C. 1740-60. L. TYPE 25. S.B.D. 2 MM. FRONT, R.H.S. OF BOWL BROKEN. IRON STAINS. BY THE SAME MAKER AS FIG. 2. NO. 10.:-W/P.

10. (3.1.83) PAUL'S WHARF.

C. 1730-60. L. TYPE 25. S.B.D. 2 MM. WIDE, THICK BOWL. OVAL/ROUND SPUR. POSSIBLY BY THE SAME MAKER AS NO. 9.:-W/P.

11. (3.12.82) QUEENHITHE.

C. 1760-80. L. TYPE 25. S.B.D. 2 MM. BACK OF BOWL FRAGMENT. LONG, THIN, OVAL SPUR, LETTERED I/H. THIN STEM.

FIG. 4.

12. (16. 10. 82) PAUL'S WHARF.

C. 1760-80. L-TYPE 25. S.B.D. 1.75 MM. THIN, WIDE BOWL. IRON STAINS AND PLUMB/RUST PATCHES, FRONT OF BOWL. TRACE OF RELIEF BOWL CROSS IN CAVITY BOTTOM. THIN, SLIGHTLY SPLAYED, OVAL BASE, LETTERED H/B.

15. (1985)

C. 1720-50. L-TYPE 25. S.B.D. 2.15 MM. NARROW BOWL, MEDIUM-THICK; GREYISH SURFACE; OVAL STEM BREAK; ROUNDISH BASE; ROSETTES ON SIDES; INTERNAL PLUNGER CROSS; CF NO. 6. (DATE RANGE GIVEN FOR THIS - 1740-70, MAY IN FACT BE EXTENDED INTO THE 1720'S).

14. (24. 7. 85)

C. 1730-60. L-TYPE 25. S.B.D. 2 MM. INTERNAL PLUNGER CROSS; FLAT, ROUND BASE; CREAMY/BUFF CLAY; R/T MAKER. CF. NO. 3. MAKER UNKNOWN.

FIG 5.

1. (8.11.82.)

C. 1740-70. L. TYPE 25. S.B.D. 2.5 MM. WHITISH CLAY, BLUE/GREY PATCHES R.H.S. LARGE ROSETTES ON ROUND SPUR.

2. (20.9.82.)

C. 1740-70. L. TYPE 25 S.B.D. 2.5 MM. WHITISH CLAY. RED BOWL CAVITY. GROOVE ON OVAL BASE. ROSETTE R.H.S ON SPUR.

3. (6.10.82.)

C. 1740-70. L. TYPE 25.SB.D. 2.5 MM. CREAM/WHITE CLAY. SOME IRON-STAINS. LARGE ROUND SPUR. 'BULL'S-EYE' ROSETTES EACH SIDE OF SPUR.

4. (6.10.82.)

C. 1740-70. L. TYPE 25. S.B.D. 2.5 MM. IDENTICAL TO NO. 3.

5. (16.11.82) - QUEENHITHE.

C. 1740-70. L. TYPE 25. S.B.D. 2.1 MM. OFF-WHITE CLAY. LIP, CHIPPED FRONT, R.H.S. SUN FACE AND THREE PIPES, EACH SIDE OF OVAL BASE.

6. (8.11.82.)

C. 1740-70. L. TYPE 25. S.B.D. 2.5 MM. WHITE/CREAM CLAY. SUN FACE R.H.S. OF ROUND SPUR.

FIG. 5.

7. (16.11.82.) - QUEENHITHE.

C. 1740-70. L. TYPE 25. S.B.D. 2 MM. LIGHT TAWNY, POLISHED CLAY.
ROUND BASE. SUN FACE, L.H.S. PIPE SIGN, R.H.S. GROOVED MARK ON INSIDE
BASE OF CAVITY.

8. (16.11.82.) - QUEENHITHE.

C. 1740-70. L. TYPE 25. S.B.D. 2.4 MM. WHITE CLAY. CRESCENT SHAPES
L.H.S. AND R.H.S. OF SPUR. SQUARE/ROUND BASE.

9. (3.1.83.) PAUL'S WHARF.

C. 1760-70. L. TYPE 25. S.B.D. 2.1 MM. SMOOTH, GREYISH WHITE CLAY. THIN LIP.
OVAL SPUR: L.H.S. W; R.H.S. A DOUBLE S IMPRESSION.

10. (3.12.82) PAUL'S WHARF.

C. 1760-80. L. TYPE 25. S.B.D. 2 MM. BACK OF BOWL FRAGMENT. BY THE SAME
MAKER AS FIG. 4, NO. 11: -I/H.

11. (3.12.82.) PAUL'S WHARF.

C. 1750-80. L. TYPE 25. S.B.D. 1.75 MM. GREYISH STEM AND BASE FRAGMENT.
THINNISH OVAL SPUR, MARKED H/S.

12. (3.1.83.) PAUL'S WHARF.

C. 1740-60. L. TYPE 25. S.B.D. 2 MM. FORWARD SLANTED SPUR, MARKED R/P. BOWL WALLS - MEDIUM.

FIG 6.

1. (21. 11. 82) - QUEENHITHE.

C. 1730-60. L. TYPE 25. S.B.D. 2.5 MM. SMOOTH, SHINY, OFF-WHITE CLAY.

THICK LIP - CHIPPED. SMALL OVAL BASE. INITIALED S/P. POSSIBLY SOLOMON PRICE(2)(3)?

2. (3. 12. 82) - QUEENHITHE.

C. 1730-60 L. TYPE 25. S.B.D. 2.3 MM. POLISHED, GREY CLAY. L.H.S. BOWL BROKEN.

R.H.S. - CHIPPED. SMOKE STAINED INSIDE CAVITY. SMALL OVAL SPUR INITIALED S/P.

A RAISED, PLUNGER CROSS ON INSIDE BASE OF CAVITY. PROBABLY BY THE SAME

MAKER AS NO. 1. THE INSIDE BASE CROSS, OCCURS IN THE MAIN C. 1720-60

ON SMALL PERCENTAGE OF BOWLS - (A. OSWALD P. 74 (d), BAR 97) .

3. (3. 12. 82) - QUEENHITHE.

C. 1730-70. L. TYPE 25. S.B.D. 2.1 MM. GREYISH, SMOOTH CLAY. AN INTERESTING S/P

BOWL WITH A THINNISH STEM, PERHAPS MAKING ITS DATE OF MANUFACTURE A

LITTLE LATER THAN NO'S 1 AND 2.

4. (6. 10. 82) BLACKFRIARS

C. 1730-60. L. TYPE 25. S.B.D. 2.3 MM. MOTTLED, TAWNY CREAM CLAY, SOME

BLUE/GREY PATCHES. OVAL/ROUND SPUR SLOPES FORWARD. INITIALED S/P.

5. (1, 2. 83.) PAULS WHARF.

C. 1730-70. L. TYPE 25. S.B.D. 2.4 MM. IRON STAINED S/P BOWL. OVAL SPUR.

FRONT OF BOWL BROKEN. WIDE MOUTH. THICK LIP. THIN STEM.

FIG 6.

6. (3.12.82.) PAULS WHARF.

C. 1730-70. L-TYPE 25. S.B.D. 2.2MM. S/P BOWL FRAGMENT. SMALL OVAL/ROUND SPUR.

7. (26.11.82.) QUEENHITHE.

C. 1730-70. L-TYPE 25. S.B.D. 2.1MM. SMALL BOWL FRAGMENT. CREAMY CLAY POSSIBLY A DIFFERENT MAKER TO NO'S 1 TO 6. SAMUEL PEARCE?

8. (8.11.82.)

C. 1730-60. L-TYPE 25. S.B.D. 2.5MM. CREAMY, OFF-WHITE CLAY. ROUND SPUR, INITIALED S ON R.H.S. RELIEF LINE ON INNER BASE, L.H.S. OF STEM HOLE PROTRUSION.

9. (3.1.83.) SOUTHWARK BRIDGE / DOWGATE.

C. 1750-80. L-TYPE 25. S.B.D. 2MM. DULL, CREAMY IRON-STAINED CLAY. BOWL - MEDIUM THICKNESS. ROUND SPUR LETTERED IN LARGE LETTERS - H/P. POSSIBLY THE SAME H/P AS THE ARMORIAL PIPE MAKER OF THE BRENTFORD EXCAVATIONS, BAR 97.

10. (14.2.83.) QUEENHITHE.

C. 1740-60. L-TYPE 25. S.B.D. 2.9MM. GREYISH-FAWN CLAY. SMOOTH, BURNISHED. LIP - MEDIUM TO THICK. INTERNAL PLUNGER MARK. ROUND SPUR, MARKED F/S WITH CROWNS. THESE HAVE CURIOUS RADIAL MARKS, POSSIBLY A DOUBLE MARK. A SUN? POSSIBLY MAKER IS FRANCIS STRAY, 1732. F. (OSWALD)

FIG. 6.

11. (14. 2. 83.) QUEENHITHE.

C. 1740-60. L-TYPE 25. S.B.D. 2.1 MM. PALE CREAMY WHITE, BURNISHED CLAY.

LP-MEDIUM, THICK. DARK SMOKE STAINS, CAVITY-BACK OF BOWL. WIDE MOUTH. SMALL SPUR,
SLOPED UPWARDS FROM STEM AXIS, MARKED I/B. A COMMON COMBINATION AT THAT TIME.

12. (14. 2. 83.) QUEENHITHE.

C. 1740-60. L-TYPE 25. S.B.D. 2 MM. MADE BY THE SAME MAKER AS FIG. 3. NO 12.

THIS PIPE ALSO HAS AN INTERNAL CROSS IN RELIEF. OVAL BASE - A FLASH OF CLAY
PROJECTING BENEATH THE R.

FIG. 7.

1. (6.10.82.)

C. 1750-70. L-TYPE 25. S.B.D. 2.5 MM. CREAMY WHITE CLAY. RED/BROWN PATCHES
L.H.S. RUST STAINING R.H.S. S/R LETTERED ON SPUR. ROUNDED SQUARE BASE.

2. (6.10.82.)

C. 1740-70. L-TYPE 25. S.B.D. 2 MM. CREAMY WHITE CLAY, WITH IRON STAINS.
SMOKE STAINS, UPPER HALF OF BOWL CAVITY. INTERNAL CROSS IN RELIEF, AXIS N.E.
OF PIPE STEM DIRECTION. OUTER BOWL LIP CHIPPED R.H.S. OVAL SPUR SLOPED
FORWARD. INITIALED W/R.

3. (3.10.82.)

C. 1740-70. L-TYPE 25. S.B.D. 2.5 MM. LIGHT CREAMY-GREY CLAY. THIN/MEDIUM
LIP THICKNESS. OVAL SPUR. 'I' L.H.S.

4. (16.11.82.) - QUEENHITHE.

C. 1740-70. L-TYPE 25. S.B.D. 2.2 MM. SMOOTH, OFF-WHITE CLAY. OVAL SPUR.
WELL DEFINED 'I', L.H.S. BLURRED 'R', R.H.S. SMOKE-STAINED INSIDE CAVITY
AND FRONT/R.H.S. OF BOWL.

5. (16.11.82.)

C. 1740-70. L-TYPE 25. S.B.D. 2 MM. OFF-WHITE CLAY. THIN/MEDIUM LIP.
ROUND SPUR INITIALED R (P?) / T. S.B. HOLE EXISTS THROUGH CENTRE OF INSIDE BASE.

FIG 7.

6. (1982).

C. 1740-60. L-TYPE 25. S.B.D. 2.5 MM. CREAMY CLAY, IRON STAINS, MOSTLY FRONT OF BOWL. I/S LETTERED ON THICK ROUND SPUR.

7. (3.12.82) - QUEENHITHE.

C. 1750-70. L-TYPE 25. S.B.D. 2.4 MM. OFF-WHITE CLAY, BLUE GREY TINGES. MEDIUM LIP, CHIPPED FRONT OF BOWL. ROUND SPUR, SLOPING FORWARD, LETTERED C/W. STEM LENGTH FROM BACK OF BASE TO BREAK - 69.5 MM.

8. (1982)

C. 1730-60. L-TYPE 25. S.B.D. 2.75 MM. BOWL THICKNESS - MEDIUM. LIP CHIPPED FRONT, L.H.S AND R.H.S. OF BOWL. HAIR-LINE CRACK L.H.S. OF BOWL. LARGE OVAL BASE. BLURRED ROSETTE L.H.S. ROSETTE R.H.S.

9. (14.2.83) QUEENHITHE.

C. 1740-60. L-TYPE 25. S.B.D. 2.1 MM. BURNISHED, CREAM CLAY, MOTTLED BLUE/GREY. THICKNESS - MEDIUM. ROUND SPUR LETTERED R/P. BY THE SAME MAKER AS FIG. 5, NO. 12.

10. (14.2.83) QUEENHITHE.

C. 1740-60. L-TYPE 25. S.B.D. 2 MM. LIP - THINNISH TO THICK AT THE FRONT. INTERNAL BOWL CROSS. ROUND SPUR, LETTERED S/P.



FIG. 7.

11. (14.2.83.) QUEENHITHE.

C. 1730-60. L. TYPE 25. S.B.D. 2.5 MM. CREAMY CLAY. FRONT OF BOWL BROKEN. MEDIUM-THICK LIP. OVAL/ROUND SPUR, SLOPED FROM STEM AXIS, LETTERED R/H.

12. (14.2.83.) QUEENHITHE.

C. 1730-40. L. TYPE 25. S.B.D. 2 MM. BLUE/GREY STAINED CLAY. BOWL FRONT BROKEN. ROUND BASE. A CURIOUS DOUBLE LETTER, L. H.S. 'A', R. H.S.

13. (22.8.85.) QUEENHITHE

C. 1730-50. L. TYPE 25. S.B.D. 2-2 MM. THICK, SMOKE BOWL; THICK, ROUND STEM - CENTRAL BORE; ROUND BASE WITH TRACE OF MOULD-LINE. CLUMSILY FINISHED WITH A BURNISHER ON STEM, BACK & FRONT OF BOWL. R/S MAKER. PERHAPS RICHARD STEELE, 1704-45, F. SOUTHWARK. 1718. T. RAM HIS APP. £5. 1745, J. PAYSON HIS APP. £5. APP. R. Cf. FIG. 2. NO. 9. ; FIG. 2 NO. 6.

FIG. 8.

1. (3.12.82) - QUEENHITHE.
 C. 1750-70. L. TYPE 25. S.B.D. 2.5 MM. WHITISH CLAY, GREY/BLACK SPOTS
 INSIDE AND OUTSIDE OF BOWL. IRON STAINS MAINLY L.H.S OF STEM. I/W AND
 PELLETS INITIALED ON SPUR.
2. (1982).
 C. 1750-70. L. TYPE 25. S.B.D. 2.0MM. WHITISH CLAY. BROWNISH STAINS.
 I/W INITIALED ON SQUARE/OVAL BASE.
3. (1982).
 C. 1750-70. L. TYPE 25. S.B.D. 2.75 MM. STEM AND BASE FRAGMENT.
 BASE-OVAL, LETTERED I/W.
4. (6.10.82).
 C. 1750-60. L. TYPE 25. S.B.D. 2.2 MM. WHITISH CLAY, IRON STAINED. SMOKE
 STAINS FRONT OF BOWL. LARGE THICK BOWL. SMALLISH ROUND SPUR, LETTERED I/W.
 THE W IN THIS CASE IS THINNER THAN THE ABOVE.
5. (3.12.82) - QUEENHITHE.
 C. 1750-70. L. TYPE 25. S.B.D. 2.3 MM. GREYISH CLAY. POLISHED. THICK LIP.
 THIN STEM. ROUND SPUR, INITIALED W/P. POSSIBLY WILLIAM PEARCE 1754, BRISTOL POLLS.

FIG 8.

6. (17. 12. 82.) NEAR SOUTHWARK BRIDGE, DOWGATE.

C. 1750-70. L. TYPE 25. S. B. D. 2.2 MM. WHITISH CLAY. OVAL SPUR. INITIALED
H/P WITH CROWNS.

7. (13. 10. 82.)

C. 1750-70. L. TYPE 25. S. B. D. 2.4 MM. WHITISH CLAY. POUCHED. SMOKE STAINS
INSIDE BOWL CAVITY. ROUND SPUR. LARGE PELLET FIGURED L.H.S. STEM LENGTH
FROM BACK OF BASE TO BREAK 83.5 MM.

8. (1982)

C. 1750-70. L. TYPE 25. S. B. D. 2.5 MM. LIGHT GREY CLAY. BACK OF BOWL BROKEN.
BOWL THICKNESS - THIN. SQUARE BASE, LETTERED I/P WITH CROWNS.

9. (14. 2. 83) QUEENHITHE.

C. 1730-50. L. TYPE 25. S. B. D. 2 MM. STEM AND BASE OF BOWL. IRON STAINS
L.H.S. OF STEM. ROUND BASE, MARKED I/O.

10. (14. 2. 83) PAUL'S WHARF.

C. 1730-50. L. TYPE 25. S. B. D. 2.4 MM. WHITE/GREY, PITTED CLAY. BOWL THICKNESS,
THINNISH TO THICK AT BACK OF BOWL. VENT L.H.S. OF STEM. OVAL SPUR, MARKED
WITH W/S IN LARGE LETTERS.

FIG. 8.

11. (14.2.83.) PAUL'S WHARF.

C. 1730. L. TYPE 25. S.B.D. 2 MM. BOWL FRAGMENT - WHITISH. SHALLOW BASE - ROUND, LETTERED W/R WITH CROWNS.

12. (14.2.83.) PAUL'S WHARF.

C. 1770-80L. TYPE 25. S.B.D. 2 MM. BASE OF BOWL AND PART OF STEM. CYLINDRICAL BASE LETTERED W/S.

13. (14.2.83.) PAUL'S WHARF.

C. 1720-40. L. TYPE 25. S.B.D. 2.6 MM. TOP OF BOWL BROKEN OVAL SPUR, LETTERED W/B. CLAY BLOTCHED WITH BLUE/GREY, IRON STAINS, AND IN WEATHERED CONDITION.

14. (2.7.85.) PAUL'S WHARF.

C. 1750-70. L. TYPE 25. S.B.D. 2 MM. COPIOUS, SMOKED BOWL; ROUND STEM BREAK - CENTRAL BORE CYLINDRICAL SPUR; T/W MAKER. A NUMBER OF POSSIBLE MAKERS.

FIG. 9.

1. (1982)

C. 1750-70. L-TYPE 25. S.B.D. 2.5 MM. GREY CLAY. SMOKE STAINS INSIDE CAVITY.
LIP CHIPPED FRONT/R.H.S. THIN. 'PINCHED' BASE, OVAL, CROWN L.H.S AND R.H.S.

2. (16.11.82.) QUEENHITHE.

C. 1750-70. L-TYPE 25. S.B.D. 2.3 MM. PROBABLY BY THE SAME MAKER AS NO. 1.

3. (26.11.82.) QUEENHITHE.

C. 1740-70. L-TYPE 25. S.B.D. 2.1 MM. BOWL BASE FRAGMENT WITH PART OF STEM.
ROUND BASE, CROWNS, L.H.S. AND R.H.S.

4. (3.10.82.)

C. 1740-70. L-TYPE 25. S.B.D. 2.5. IRON STAINED STEM AND BASE FRAGMENT,
SIMILAR TO NO. 3, AND POSSIBLY BY THE SAME MAKER.

5. (21.11.82.) QUEENHITHE.

C. 1730-60. L-TYPE 25. S.B.D. 2.4 MM. GREYISH CLAY. LARGE, THINNISH BOWL.
LARGE, OVAL BASE. CROWNS AND ROSETTES EACH SIDE OF SPUR.

6. (16.11.82.) - QUEENHITHE.

C. 1730-60. L-TYPE 25. S.B.D. 2.5 MM. GREYISH POLISHED CLAY. STAR PATTERN IN
RELIEF, WITH CIRCLE SURROUND, ON BASE. CROWNS AND ROSETTES, SIDES OF SPUR.

FIG. 9.

7. (1982)

C. 1730-60. L. TYPE 25. S.B.D. 3 MM. POLISHED CREAMY CLAY WITH IRON STAINING.
 ONLY BACK, LOWER PART OF BOWL REMAINING. MEDIUM THICKNESS. THICK STEM.
 LARGE, ROUND BASE. CROWNS AND ROSETTES ON EDGES OF SPUR.

8. (16. 11. 82) QUEENHITHE.

C. 1730-60. L. TYPE 25. S.B.D. 2 MM. WHITISH BASE AND STEM FRAGMENT.
 IDENTICAL BASE AND SIDE OF SPUR STAMPS AS NO. 6.

9. (20. 9. 82).

C. 1730-60. L. TYPE 25. S.B.D. 2.5 MM. WHITISH FRAGMENT OF BASE AND STEM.
 ROUND/SQUARE BASE. CROWN AND ROSETTE MARKS L.H.S. AND R.H.S.

10. (3. 1. 83.) SOUTHWARK BRIDGE/DOWGATE.

C. 1730-60. L. TYPE 25. S.B.D. 2.4 MM. OFF-WHITE CLAY. ROUND BASE, WITH 'H'
 IN RELIEF WITHIN A STAMPED CIRCLE. ROSETTES AND CROWN SIDES OF SPUR.

11. (3. 12. 82) PAUL'S WHARF.

C. 1750-80. L. TYPE 26. S.B.D. 1.75 MM. FRONT OF BOWL BROKEN, AND SPUR.
 SMOKE-STAINS IN CAVITY. FORWARD POINTED SPUR, MARKED I/B. A COMMON COMBINATION.

FIG. 9.

12. (17. 12. 82) PAUL'S WHARF.

C. 1770-80. L. TYPE 26. S.B.D. 2 MM. GREYISH, MOTTLED SURFACE; SHINY, SMOOTH.

EXAGGERATED, FORWARD POINTING SPUR, FLATTENED AT 'TOE'. LETTERED S/P.

13 (14. 2. 83). QUEENHITHE.

C. 1750-80. S.B.D. 2.1 MM. UNMARKED BOWL FRAGMENT WITH PART OF ARMORIAL

DESIGN (PROBABLY SIMILAR TO BAR 97, P. 125, NO. 52) FRAGMENT HAS PART OF MOTTO:-

DIEU ET MON DROIT AND PART OF THE WHITE HORSE OF HANOVER.

14. (3. 12. 82) PAUL'S WHARF.

C. 1750-80. S.B.D. 2 MM. BOWL / SPUR FRAGMENT SHOWING PART OF HANOVERIAN ARMS.

POSSIBLY A LETTER 'M' ON R.H.S. OF SPUR.

FIG. 10.

1. (16.11.82) QUEENHITHE.

C.1730-60. L. TYPE 25. S.B.D. 2.3 MM. WHITISH CLAY WITH IRON STAINS. BOWL FRONT
BROKEN. OVAL SPUR WITH GAUNTLET MARK IN RELIEF L.H.S. SIMILAR FROM DORKING,
BAR 97, P. 255.

2. (3.12.82) QUEENHITHE.

C.1720-40. L. TYPE 25. S.B.D. 2.4 MM. SMOOTH, POLISHED, OFFWHITE CLAY. SMOKE STAINS
UPPER PART OF BOWL CAVITY. OVAL/ROUND BASE, LETTERED A/S IN LARGE CAPITALS.

3. (3.12.82) QUEENHITHE.

C.1730-50. L. TYPE 25. S.B.D. 2.5 MM. CREAMY CLAY, THICK BOWL; SMOKE-STAINS
INSIDE CAVITY. ROUND SPUR, WITH CROWN AND HARP R.H.S. AND L.H.S.

4. (10.10.82)

C.1730-50. L. TYPE 25. S.B.D. 2.5 MM. CREAMY CLAY, MEDIUM BOWL THICKNESS;
IRON STAINS. SMOKE STAINS INSIDE AND POSSIBLY OUTSIDE, L.H.S. ROUND SPUR, CROWN
AND HARP, L.H.S. AND R.H.S.

5. (3.10.82)

C.1730-50. L. TYPE 25. S.B.D. UNKNOWN. BOWL FRAGMENT, MEDIUM THICKNESS. SIMILAR
MARKS TO NO'S 3 AND 4, THOUGH ALL OF THESE DIFFERING TO SOME DEGREE.

FIG. 10.

6. (31. 1. 82.) BROOK'S WHARF.

C. 1730-60. L. TYPE 25. S. B. D. 2.5 MM. CREAMY/BUFF CLAY, IRON STAINS, GREY/BLUE PATCH R. H. S. OF BOWL; SMOKE STAINS INSIDE BOWL CAVITY. LIP, WIDE AND THICK. SMALL, ROUND BASE, INITIALED POSSIBLY H/S.

7. (31. 1. 82.) QUEENHITHE.

C. 1730-50. L. TYPE 25. S. B. D. 2 MM. GREYISH, OFF-WHITE CLAY, POLISHED. THICK WIDE LIP. SMOKE STAINS INSIDE CAVITY. OVAL BASE, LETTERED I/D.

8. (31. 1. 82.) PAUL'S WHARF.

C. 1750-70. L. TYPE 25. S. B. D. 1.6 MM. FRAGMENT OF A WILLIAM TAPPIN BOWL. PROBABLY A LATE ONE, GIVEN STEM AND BORE HOLE THICKNESS. THERE IS A TRACE OF A PLUNGER RELIEF LINE ON THE CAVITY BASE.

9. (16. 11. 82) QUEENHITHE.

C. 1750-80. S. B. D. 1.8 MM. CREAMY, WHITE, THINNISH BOWL; SPUR BROKEN WITH LETTERS R/B. HANOVARIAN ARMS ON BACK; FRONT BLANK. MOTTO MISPELT: HONI (SOIT) QUI NAL Y PEN(E). POSSIBLY MADE BY ROBERT BALDWIN WORKING IN WESTMINSTER, 1749. MOTTO ON RIBBON HAS A REVERSED 'N'.

10. (16. 11. 82) PAUL'S WHARF.

C. 1750-80+ L. TYPE 26. S. B. D. 2.5 MM. PART OF ARMORIAL BOWL, BEARING THE HANOVARIAN ARMS, LETTERED S/P ON SPUR. VERY PROBABLY TOO LATE FOR SOLOMON PRICE (2)



FIG 10.

11. (3.10.82) PAUL'S WHARF.

C. 1750-80.

S.B.D. 2 MM. ARMORIAL BOWL FRAGMENT BEARING

HANOVARIAN ARMS. CLAY HAS SHINY, BONE-LIKE QUALITY. LETTER 'W' L.H.S. OF SPUR.

FIG. 11.

1. (14. 2. 83.) PAUL'S WHARF.

C. 1750-80. S.B.D. UNKNOWN. BOWL PIECE (L.H.S.) SHOWING PART OF HANNOVERIAN ARMS. LION COURANT ON TOP OF CROWN. COMPARE BAR 97, P.125 NO.27.

2. (3. 12. 82.) BROOK'S WHARF.

C. 1760-80. S.B.D. 1.9 MM. THINNISH, SEMI-POLISHED PIPE. SMOKE-STAINS IN CAVITY. SPLAYED, OVAL BASE. STEM, OVAL. BACK OF BOWL SHOWS AN UNKNOWN ARMORIAL DEVICE OF A LION RAMPANT IN A SHIELD; ABOVE, A LION (OR UNICORN?) RAMPANT HOLDING A SLIP OR FLAIL. H/P LETTERED ON SPUR. FEATHERED DESIGN ON FRONT MOULD-LINE. COMPARE BAR 97, P. 105, NO. 4. AND P. 48, NO. 37.

3. (26. 11. 82.) QUEENHITHE.

C. 1750-80. L. TYPE 25. S.B.D. 2 MM. BOWL FRAGMENT WITH OVAL/ROUND SPUR LETTERED R/C. FLOWER PATTERN ON BOWL FRONT. THISTLES BACK AND SIDES. POSSIBLY, ROSE AND THISTLE DEVICE SIMILAR TO BAR 97, P. 105, NO. 1.

4. (28. 2. 83.) BLACKFRIARS/ PAUL'S WHARF.

C. 1730-60. L. TYPE 25 S.B.D. 2 MM. OFF-WHITE CLAY; FRONT OF BOWL BROKEN. SQUAT, ROUNDISH BASE. MAKER - S/P. THIS IS THE 'SMALL' S/P MARK. THE LETTERS BEING THICKER AND SMALLER THAN THE 'LARGE' S/P MARK.

5. (28. 2. 83.) BLACKFRIARS/ PAUL'S WHARF.

C. 1730-60. L. TYPE 25. S.B.D. 2 MM. A CRUSTATED S/P BOWL, FRONT BROKEN.

FIG 11.

6. (28.2.83.) BLACKFRIARS / PAUL'S WHARF.
 C. 1720-40. L. TYPE 25. S.B.D. 2.60 MM. THICK, UPRIGHT BOWL, DAPPLED BLUE/GREY.
 SQUAT, ROUNDISH BASE. MAKER I/B. POSSIBLY JOHN BAYLEY, 1719-31, ST. BOTOLPHS.
 BUT MANY OTHER POSSIBILITIES.

7. (28.2.83.) BLACKFRIARS / PAUL'S WHARF.
 C. 1740-60. L. TYPE 25. S.B.D. 2.4 MM. VERY GRIMY CLAY; L.H.S. OF BOWL BROKEN.
 CYLINDRICAL, UPRIGHT SPUR. THINNISH STEM. MAKER - T/P, OR POSSIBLY I/P.

8. (28.2.83.) BLACKFRIARS / PAUL'S WHARF.
 C. 1740-70. L. TYPE 25. S.B.D. 1.9 MM. SMOOTH, SHINY BOWL, MEDIUM THICKNESS.
 CYLINDRICAL BASE. MAKER I/E.

9. (28.2.83.) BLACKFRIARS / PAUL'S WHARF.
 C. 1740-70. L. TYPE 25. S.B.D. 2 MM. SMOOTH, LARGE BOWL, MEDIUM THICKNESS.
 SQUARISH BASE. MAKER I/S.

10. (28.2.83.) BLACKFRIARS / PAUL'S WHARF.
 C. 1740-70. L. TYPE 25. S.B.D. 1.9 MM. GREY, MOTTLED CLAY. LARGE, CYLINDRICAL BASE.
 PELLET IN RELIEF R.H.S.; L.H.S. MARK SPOILED. IN THE CENTRE OF THE BASE, ALONG MOULD-LINE
 IS AN ACCIDENTAL OR DELIBERATE GROOVE.

FIG. 11.

11. (9.9.83.) QUEENHITHE.

C. 1720-40. L-TYPE 25. S.B.D. 2.5 MM. THICK BOWL FRAGMENT. ROUND GASE. CROWN AND ROSETTE MOTIFS, SIDE OF GASE. ROUND PETALS IN DOUBLE OUTLINE.

12. (22.9.83.) PAUL'S WHARF.

C. 1720-40 L-TYPE 25. S.B.D. 2.1 MM. THICK STEM. SMALL, SHALLOW GASE. MAKER R/P OR R/R. 'SCORE' OR 'SCUFFLE MARKS ON INNER GASE.



FIG. 12.

1. (28.2.83.) BLACKFRIARS / PAUL'S WHARF.

C. 1730-60. L-TYPE 25. S.B.D. 1.6 MM. DISCOLOURED BOWL FRAGMENT ; ROUND BASE. MAKER, I/G.

2. (28.2.83.) BLACKFRIARS / PAUL'S WHARF.

C. 1730-60. L-TYPE 25. S.B.D. 2 MM. BACK OF BOWL FRAGMENT. ROUND, FLAT SPUR. MAKER, R/T. A COMBINATION OF LETTERS UNLISTED FOR THIS PERIOD BY OSWALD.

3. (28.2.83.) BLACKFRIARS / PAUL'S WHARF.

C. 1730-60. L-TYPE 25. S.B.D. 2.5 MM. LARGE, THICK BOWL, MOTTLED. ROUND BASE. MAKER, W/M. CROWNS ABOVE LETTERS. A TYPICAL MARKING OF WILLIAM MAMBY (2), (ATTRIBUTED), WORKING 1719-63.

4. (28.2.83.) BLACKFRIARS / PAUL'S WHARF.

C. 1730-60. L-TYPE 25. S.B.D. 1.95 MM. BASE AND STEM PIECE. UNUSUAL MAKER'S INITIALS WITH ROSETTES. GROOVED LINE ON BASE.

5. (28.2.83.) BLACKFRIARS / PAUL'S WHARF.

C. 1750-80. L-TYPE 26. S.B.D. 1.75. ARMORIAL-TYPE BOWL FRAGMENT BUT WITH NO INDICATION OF DESIGN. MARK VERY SIMILAR TO FIG. 1., NO. 10. A 'FIGURE-OF-EIGHT' TYPE CROWN. THE INTERNAL RELIEF CROSS ON BASE COULD DATE PIPE BEFORE 1760. (OSWALD) ALTHOUGH THERE ARE EXCEPTIONS TO THE RULE HOWEVER.

FIG. 12.

6. (28. 2. 83.) BLACKFRIARS/PAUL'S WHARF.

C. 1750-70. (TYPOLOGICAL DATE, 1700-40.) S.B.D. 2.2 MM. A CLEAR STAMP OF WILLIAM TAPPIN'S, ON THE SQUAT, OVAL BASE; UPRIGHT, THICK BOWL; THICK STEM; TYPICAL 1720'S PIPE, THOUGH TAPPIN WAS WORKING IN BLACKFRIARS IN 1763.

7. (28. 2. 83.) BLACKFRIARS/PAUL'S WHARF.

C. 1750-70. (TYPOLOGICAL DATE, 1700-40.) S.B.D. 2.3 MM. DISCOLOURED BOWL FRAGMENT, OVAL BASE WITH TAPPIN'S MARK.

8. (28. 2. 83.) BLACKFRIARS/PAUL'S WHARF.

C. 1750-70. (TYPOLOGICAL DATE, 1700-40.) S.B.D. 2.5 MM. PART OF UPRIGHT, TAPPIN BOWL. THE BASE NARROWING INTO AN OVAL SPUR. STAMP, OFF-CENTRE.

9. (13. 5. 83.) QUEENHITHE.

C. 1750. L. TYPE 25. S.B.D. 2.2 MM. BROKEN BOWL WITH ARMORIAL DESIGN OF A HARP ON BACK. CYLINDRICAL SPUR. MAKER R/B. SAME AS : BAR 97, P. 169, NO. 45. BUT IN THAT EXAMPLE R.H.S. INITIAL IS OBSCURED. PROBABLY MAKER IS : ROBERT BALDWIN, 1749, CHYMISTER ALLEY, ST. MARTINS, WESTMINSTER POLLS.

10. (25. 3. 83.) TRIG LANE STAIRS/BLACKFRIARS.

C. 1750-80. L. TYPE 26. S.B.D. 2.5 MM. BLACKENED BOWL, FRONT BROKEN, WITH POINTED SPUR, LETTERED S/P. LIKELY TO BE A PIPE MADE BY SAMUEL PEARCE, 1784, BRISTOL POLLS, SO POSSIBLY LATER THAN 1780.

FIG. 12.

11. (14. 4. 83.) SOUTHWARK BRIDGE.

C. 1720-40. S.B.D. 2 MM. UNUSUAL MUSHROOM COLOURED BOWL, THICK,
TOP/BACK BROKEN, WITH THICK STEM AND VERY SMALL SPUR. UNCLASSIFIED.

12. (11. 9. 85.) QUEENHITHE.

C. 1740-60. L-TYPE 25. S.B.D. 2 MM. CREAMY SURFACE; BURNISHING STROKES ON BACK & STEM SEAMS;
CHIPPED, ROUND GAGE; R/P MARKER. ROBERT PHIPPS, 1740. APP. R. APP. TO W. WILDER £3; ROBERT
PATTISON, 1755. GOULD ST. BERMONDSEY £400. SU. ASS.; RICHARD PINKARD. 1761. OLD MONTAGUE ST
WHITECHAPEL. £200 SU. ASS.

FIG. 13.

1. (28.2.83) BLACKFRIARS / PAUL'S WHARF.

C. 1750-70. (TYPOLOGICAL DATE, 1700-40. S.B.D. 2.5 MM. WEATHERED BOWL, BACK BROKEN OFF. AGAIN, THE LOWER PART NARROWS TO AN OVAL BASE. W. TAPPIN'S STAMP.

2. (28.2.83) BLACKFRIARS / PAUL'S WHARF.

C. 1750-70. (TYPOLOGICAL DATE, 1700-40. S.B.D. 2.2 MM. PITTED BOWL, SIMILAR TO NO. 1. THOUGH NARROWER STILL AT THE BASE (OVAL). THE STAMP IS HARDLY REPRESENTATIVE OF THE MAKER, W. TAPPIN, ONLY PART OF IT BEING VISIBLY ON THE NARROW OVAL.

3. (28.2.83) BLACKFRIARS / PAUL'S WHARF.

C. 1750-70. (TYPOLOGICAL DATE, 1700-40. S.B.D. 2.5 MM. ONE OF WILLIAM TAPPIN'S BETTER QUALITY MOULDS, WITH BURNISHED CLAY AND CLEAR, CENTRAL STAMP ON LARGE BASE. BLACK PATCH L.H.S. OF BOWL. TOP OF BOWL BROKEN OFF.

4. (28.2.83) QUEENHITHE.

C. 1720-40. L. TYPE 25. S.B.D. 2.5 MM. WIDE, SHINY, THICKISH BOWL. CONCAVE BASE. MAKER A/S. POSSIBLY, ABRAHAM SHEPHARD, 1721, POPLAR, OR ABRAHAM SANDS, 1725.

5. (28.2.83) QUEENHITHE.

C. 1720-40. K. TYPE 25. S.B.D. 2 MM. NARROW, THICK TO MEDIUM BOWL. BURNISHED. BACK OF LIP BROKEN. SMOKE-STAINS IN CAVITY. THICK, DISCOLOURED STEM. OVAL BASE. MAKER I/T. POSSIBLY JOHN THORPE, 1717, WHITECHAPEL, OR JOSEPH TINE, 1726, DIED, CLERKENWELL.



FIG. 13.

6. (28.2.83.) QUEENHITHE.

C. 1740-60. L. TYPE 25. S.B.D. 2 MM. SEMI-POLISHED, IRON STAINED BOWL; L.H.S. LIP CHIPPED OFF. SMOKE-STAINS IN CAVITY. LONG CYLINDRICAL SPUR. MAKER W/H. PROBABLY WILLIAM HEATH WORKING IN BRENTFORD AT THIS TIME.

7. (28.2.83.) QUEENHITHE

C. 1730-50. L. TYPE 25. S.B.D. 2.5 MM. FRONT/R.H.S. OF BOWL BROKEN. ROUND BASE, WITH FLASH AT STEM JOIN. MAKER: I/M. CROWNS ABOVE LETTERS. THICKISH STEM. POSSIBLY JOSEPH MOORE, 1723 OR JOSEPH MILSON, 1739, BRISTOL POLLS.

8. (23.6.83.) PAUL'S WHARF.

C. 1720-40. L. TYPE 25. S.B.D. 2.15 MM. THICK, WEATHERED BOWL, ROUND BASE, SMALL HARP MOTIFS EACH SIDE. THICK STEM. UNUSUAL, THIS MARK NORMALLY INCLUDES CROWN ABOVE.

9. (23.6.83.) PAUL'S WHARF.

C. 1720-40. L. TYPE 25. S.B.D. 2.25 MM. TALL, THICK, DISCOLOURED BOWL, WITH BASE MISSING L.H.S. THICK STEM. MARKS: W/M BELOW CROWN. ATTRIBUTED TO WILLIAM MANBY, (2) 1719-63.

10. (23.6.83.) TRIG LANE STAIRS / BLACKFRIARS.

C. 1750-70. L. TYPE 25. S.B.D. 2.1 MM. LARGE, UPR-LIPPED BOWL, SMOOTH CLAY, NARROWING TO OVAL BASE. LETTERED: I/H. SEVERAL POSSIBLE MAKERS.



FIG. 13.

11. (23.6.83.) TRIG LANE STAIRS / BLACKFRIARS.

C. 1750-70. L. TYPE 25. TYPOLOGICAL DATE 1720-40. S.B.D. 2.03 MM. LARGE THICK BOWL, NARROWING TO CHIPPED BASE WITH OBSCURED WILLIAM TAPPIN'S MARK.

12. (16.9.85.) QUEENHITHE.

C. 1720-40. L. TYPE 25. S.B.D. 2.75 MM. THICK, SMOKED, COPIOUS BOWL; POLISHED; LIGHT GREY/FAWN; ROUND BASE; SMALL R/S LETTERS OF MAKER. cf LARGER LETTERS THAT SIGN THE BOWLS OF FIG. 19, NO. 9; FIG. 20., 7; FIG., NO. 10. POSSIBLE MAKERS: RICHARD STEELE, 1704-45 F. SOUTHWARK. 1718. T. RAM HIS APP. £5. 1745. J. PAYSON HIS APP. £5. APP. R.; RICHARD SPARKS, 1712. APP. R. ST. JAMES ST. WINSTER. APP. TO MARY COOPER. £5.; RICHARD SANDS, 1728. F ROBERT SMITH, 1732. APP. R. APP. TO HEMPSTEAD MULES. ST. GEORGE WEST. R.

FIG. 14.

1. (28.2.83) QUEENHITHE.

C. 1750-50. L. TYPE 25. S.B.D. 2.5 MM. BOWL OF MEDIUM THICKNESS, POLISHED. MOTTLED CLAY. FRONT LIP CHIPPED OFF. OVAL BASE. MAKER: C/W.

2. (28.2.83) QUEENHITHE.

C. 1740-60. L. TYPE 25. S.B.D. 2.5 MM. THICKISH BOWL, SMOOTH; SMOKE-STAINED AND IRON STAINS IN CAVITY; BASE - ROUND. CURIOUS 'REVERSE' G PERHAPS, L. H.S. AND S. R.H.S.

3. (28.2.83) QUEENHITHE.

C. 1740-70. L. TYPE 25. S.B.D. 2.1. SMOOTH, SHINY, PINKISH BOWL; SPECKLED CLAY. SMALLISH, ROUND SPUR. MAKER R/T.

4. (28.2.83) QUEENHITHE.

C. 1730-50. L. TYPE 25. S.B.D. 2.1 MM. THICK, BURNISHED, GREYISH PIPE. LIP CHIPPED OVAL BASE. MAKER W/P. INTERNAL PLUNGER CROSS IN RELIEF.

5. (28.2.83) QUEENHITHE.

C. 1770-80. L. TYPE 25. S.B.D. 2 MM. BURNISHED BOWL, TOP BROKEN OFF; SMALL, OVAL SPUR. THIN STEM. MAKER I/A. POSSIBLY JOHN ADDS, 1761, STRAND

FIG 14.

6. (28.2.83.) QUEENHITHE.

C. 1730-50. L. TYPE 25 S.B.D. 2 MM. THICK, GREY BOWL. THICKISH STEM. ROUND SPUR.
MAKER S/P.

7. (28.2.83.) QUEENHITHE.

C. 1730-50. L. TYPE 25. S.B.D. 2.5 MM. IRON-STAINED S/P BOWL, FRONT LIP BROKEN OFF.
SLOPING SPUR WITH FLASH.

8. (14.4.83.) QUEENHITHE.

C. 1720 L. TYPE 25. S.B.D. 2.5 MM. BASE/STEM FRAGMENT. MAKER I/G. CROWNS
ABOVE LETTERS. SOME IRON STAINING. BASE DROPPED SLIGHTLY FORWARD.
A NUMBER OF POSSIBILITIES INCLUDING: JOHN GUY (2) 1712 ST. DUNSTONS
STEPNEY.

9. (14.4.83.) QUEENHITHE.

C. 1740-60. L. TYPE 25. S.B.D. 2.1. BOWL/BASE FRAGMENT OF BURNISHED,
CREAMY-GREY FABRIC, SMALL ROUND BASE, WITH MAKER'S INITIALS: F/S.
CROWNS ABOVE LETTERS. POSSIBLY FRANCIS STRAY (STACE, STAW) 1732. F.
SEE FIG. 6, NO. 10 FOR COMPLETE BOWL.

10. (14.4.83.) QUEENHITHE.

C. 1720. L. TYPE 25. S.B.D. 2.1. MM. UPRIGHT BOWL WITH SMALLISH, ROUND
BASE. SMOKE-STAINED CAVITY. LIP CHIPPED - FRONT. SMALL, HIGH, LETTERS OF MAKER:
R/T. UNLISTED.

FIG. 14.

11. (14.4.83) QUEENHITHE.

C. 1740-60. L-TYPE 25. S.B.D. 2.1 MM. BOTTOM L.H.S. OF BOWL AND STEM, WITH SMALL, ROUND BASE. MAKER: I/P. OR R/P. POSSIBLY JOHN PINKARD(?) OR ROBERT PHIPPS, 1740.

12. (14.4.83) QUEENHITHE.

C. 1720-40. L-TYPE 25. S.B.D. 2.1 MM. NARROW, UPRIGHT BOWL, MEDIUM THICK. CREAMY-MUSHROOM, BURNISHED FABRIC. SPLAYED, OVAL BASE. A/S. SMALL LETTERS. POSSIBLY ABRAHAM SHEPHARD, 1721 OR ABRAHAM SANDS, 1725, F.
Cf. FIG. 10, NO. 2, AND FIG. 13. NO. 4.

13. (2.7.85) PAUL'S WHARF.

C. 1750-80. L-TYPE 26. S.B.D. 2 MM. WELL ENGRAVED HANNOVERIAN ARMS; ROUND STEM BREAK - CENTRAL BORE; FLAT BOTTOMED SPUR. UNSIGNED.

14. (2.7.85) PAUL'S WHARF.

C. 1750-70. L-TYPE 25. S.B.D. 1.9 MM. SMOKED, DISCOLOURED FRAGMENT; OVAL BASE WITH MARK ATTRIBUTED TO WILLIAM TAPPIN (1763. BLACKFRIARS. £100. SU. ASS.). PART OF CAVITY CROSS INTACT. ONE OF TAPPIN'S 'SLIM-LINE' PIPES, WHICH SEEM RARER THAN THE EARLIER (18th) TYPES HE SEEMED TO PRODUCE.

15. (2.7.85) PAUL'S WHARF.

C. 1740-60. L-TYPE 25. S.B.D. 2.05 MM. EVENLY THICK BOWL; ROUND STEM-BREAK - CENTRAL BORE; CHIPPED STEM (BELOW); SMOOTH, BRONZISH CREAMY SURFACE; SMOOTH OVAL BASE; S/P MAKER; CAVITY CROSS.

FIG. 15.

1. (14.4.83) QUEENHITHE.

C. 1720-40. L-TYPE 25. S.B.D. 2.6 MM. BROAD, THICK BOWL WITH TAPERING BASE TO SMALL, OVAL BASE. MAKER: R/H. SEVERAL POSSIBILITIES, O.A. 1696.

2. (14.4.83) QUEENHITHE.

C. 1730-60. L-TYPE 25. S.B.D. 2.1 MM. S/P BOWL. GREY, DISCOLOURED SURFACE, FRONT, R.H.S. BROKEN (LIP). CYLINDRICAL SPUR, TRUNKATED AT TANGENT SLOPING DOWN.

3. (14.4.83) QUEENHITHE.

C. 1740-60. L-TYPE 25. S.B.D. 2.2 MM. BACK PART OF BOWL WITH BASE. MAKER C/S. POSSIBLY CHARLES STEWART, FREE 1718, SEE BAR 97, P'S 30, 29, 45, NO. 12.

4. (14.4.83) QUEENHITHE.

C. 1730-60. L-TYPE 25. S.B.D. 2.45 MM. BASE OF S/P BOWL WITH PLUNGER CROSS IN CAVITY. CYLINDRICAL BASE. 'P' BLURRED.

5. (14.4.83) QUEENHITHE.

C. 1750-70. L-TYPE 25. S.B.D. 2.4 MM. THICK, UPRIGHT TAPPIN BOWL, TAPERING TO OVAL BASE, STAMP PARTLY OBSCURED.



FIG. 15.

6. (26. 4. 83.) BROKEN WHARF.

C. 1720-40. L-TYPE 25. S.B.D. 2.2 MM. DISCOLOURED, PALE GREY-FAWN CLAY. ROUND BASE, SLOPING FORWARD. MAKER T/W. POSSIBLY THOMAS WOOD, 1706-40, F. CLERKENWELL, ALTHOUGH THERE ARE OTHER POSSIBILITIES.

7. (14. 4. 83.) PAUL'S WHARF.

C. 1750-60. L-TYPE 25. S.B.D. 1.9 MM. BOWL WITH FRONT BROKEN: THIN STEM; OVAL BASE. VERTICAL PLUNGER LINES IN CAVITY. NARROW INTERNAL BASE MAKER R/C. PROBABLY RICHARD COLS (2) 1742-1800. 1742, APP. TO T. FOSTER £5 APP. R. 1763, WHITECROSS ST. Cf. FIG. 3, NO. 12. & NO. 7; FIG. 6. NO. 12; FIG. 11. NO. 3.

8. (14. 4. 83.) PAUL'S WHARF.

C. 1730-50. L-TYPE 25. S.B.D. 2 MM. BASE/STEM FRAGMENT WITH TRACES OF VERTICAL PLUNGER LINE. SHALLOW, ROUND BASE. MAKER R/R. OR R/B. POSSIBLY ROBERT ROBINSON, 1722. F; ROBERT ROBELL, 1737.

9. (14. 4. 83.) PAUL'S WHARF.

C. 1730-50. L-TYPE 25. S.B.D. 2.3 MM. BOWL WITH FRONT/L.H.S. BROKEN, REVEALING INTERNAL PLUNGER CROSS. SMOOTH WHITISH SURFACE. SMALL OVAL BASE. MAKER: W/S. Cf. FIG. 8. NO 10. A NUMBER OF POSSIBLE MAKERS.

FIG. 16.

1. (29.3.83.) PAUL'S WHARF.

C. 1750-60. L. TYPE 25. S.B.D. 2.5 MM. LARGE, MEDIUM, THIN BOWL; CHIPPED LIP, L.H.S. SMOKE-STAINS IN CAVITY. SURFACE OF CLAY DISCOLOURED. WELL-FINISHED, FLAT-BOTTOMED BASE, TENDING DOWNWARDS. LETTERS WITH CROWNS: R/P.

Cf. FIG. 5, NO. 12; FIG. 14, NO. 11; FIG. 7, NO. 9. POSSIBLY SAME MAKER, BUT LETTERS SMALLER. SUGGESTED MAKER: ROBERT PHIPPS, 1740 OR ROBERT PATTISON, 1755, GOULD ST. BERMONDSEY

2. (14.4.83.) PAUL'S WHARF.

C. 1750-80. L. TYPE 26. S.B.D. 2.1 MM. BATTERED ARMORIAL PIPE WITH THE HANOVARIAN ARMS BACK OF BOWL, FEATHER OR LEAF DESIGN ON FRONT SEAM. SPUR BROKEN. FRACTION OF SURNAME LETTER VISIBLE - THE LEFT HAND UPRIGHT OF CAPITAL - ONE OF MANY: B, D, E, F, H, I, K, L, M, N, P, R, MORE PROBABLY AN F, H, I, M, N, P, R, JUDGING BY THE BOTTOM SERIF. BUT THE PIPE REMAINS UNIDENTIFIED. STEM LENGTH FROM SPUR BACK TO BREAK: 114 MM. PERHAPS W. HEATH. SEAM PATTERN & LION'S TALE FIT BAR 78, P'S 375 & 379 EXAMPLES.

3. (29.3.83.) THREE CRANES WHARF.

C. 1750-80. L. TYPE 25. S.B.D. 2 MM. ARMORIAL BOWL WITH HANOVARIAN ARMS. MOTTO: SEMPER EADEM ON RIBBON. SOME IRON-STAINING. MAKER H/P. HANOVARIAN H/P BOWLS ARE USUALLY ATTRIBUTED TO HUMPHREY PARBATT, 1729, ST. GEORGE IN EAST.

FIG. 15.

10. (14.4.82.) PAUL'S WHARF.

C. 1740-60. L. TYPE 25. S.B.D. 1.75 MM. S/P PIPE WITH FRONT BROKEN; LARGE CIRCULAR BASE; LARGE LETTERS; THIN STEM, WITH SHINY SURFACE.

11. (29.3.83.) PAUL'S WHARF.

C. 1720-50. L. TYPE 25. S.B.D. 2.1 MM. THICK PIPE WITH SQUARISH MOUTH OPENING; THICK STEM. SMALL ROUND BASE, ROSETTES L.H.S & R.H.S. Cf. FIG. 4, NO'S 6, 7, 8.

12. (29.3.83.) PAUL'S WHARF.

C. 1720-50 L. TYPE 25. S.B.D. 2 MM. BOWL WITH TOP BACK/ R.H.S. BROKEN; BLUE/GREY PATCHES AND IRON STAINS R.H.S. SQUARISH BASE. MAKER. W/P. POSSIBLY WILLIAM PINKARD, 1696. FREE, 1708-1715, HUDSON BAY EXPORTER. WHITECHAPEL. Cf. BAR 97, P. 48. NO. 28. Cf. ALSO, ABOVE, FIG. 2, NO. 10; FIG. 4, NO'S. 9 & 10.



FIG. 16.

4. (26.4.83.) PAUL'S WHARF.

C. 1730-50. L. TYPE 25. S.B.D. 1.98 MM. BOWL WITH SMALL, ROUND BASE. MEDIUM THICKNESS. HAIRLINE-CRACK L.H.S. FLAT INTERNAL BASE. MAKER T/W. SEVERAL POSSIBLE MAKERS.

5. (29.3.83.) PAUL'S WHARF.

C. 1720-40. L. TYPE 25. S.B.D. 2.2 MM. BOWL FRAGMENT WITH OVAL BASE. MAKER W/M. CROWNS ABOVE LETTERS. W MARK SLURRED, POSSIBLY BY THE ADDITION OF ANOTHER LETTER, LIKELY TO BE WILLIAM MANBY (2) 1719-63, WORKING GREEN DRAGON ALLEY. 1763, HERMITAGE BDGE. KIDNEY STAIRS, LIMEHOUSE.

6. (29.3.83.) PAUL'S WHARF.

C. 1750-70. L. TYPE 25. S.B.D. 2.1 MM. THICK, NARROW, UPRIGHT BOWL; LIP CHIPPED L.H.S. IRON STAINS R.H.S. BASE STAMP CLUMSILY IMPRESSED LEAVING A DOUBLE MARK. ALTHOUGH THE TYPOLOGY OF THIS BOWL POINTS TO THE 1720'S, THE STAMP IS OF WILLIAM TAPPIN WHO WAS WORKING AT BLACKFRIARS, 1763 AND PROBABLY THE PIPE DATES AT AROUND THIS TIME. THERE IS LITTLE EVIDENCE THAT TAPPIN'S PIPES, FOUND IN THE THAMES AT BLACKFRIARS, HAD BEEN AT ALL MODIFIED TO THE CONTEMPORARY LINES. IN THE MAIN THE FINDS CONFORM TO THE 1720-40 TYPE OF PIPE. THOUGH SOME, E.G. FIG. 1 NO. 3, HAVE SLIMMER BASES, OFTEN THE OLD, LARGE STAMPS WERE STILL APPLIED. HOWEVER SOME, FIG. 3, NO 2, FIG. 10. NO. 8 COULD BE FITTED INTO THE TYPOLOGY OF THE 1740-60 ERA.

FIG. 16.

7. (13.5.83) TRIG LANE STAIRS / BLACKFRIARS.

C. 1760-80. L-TYPE 25. S.B.D. 1.9 MM. LARGE BOWL, TAPERING TO BASE. OVAL SPUR, SLOPING DOWNWARDS. DISCOLOURED AND IRON-STAINED, MORE SO BACK AND L.H.S. MAKER I/A. POSSIBLY JOHN ADDS, 1761, STRAND, MAIDSTONE POLLS.

8. (13.5.83) QUEENHITHE.

C. 1720-40. L-TYPE 25. S.B.P. 2.2 MM. SMOOTH, SHINY BOWL, THICK, TAPERING TO BASE. OVAL/ROUND BASE. MAKER H/M. POSSIBLY HEMPSTEAD MULES (HAMPSTEAD), 1723-32. ST. GEO., WESTMINSTER.

9. (13.5.83) TRIG LANE STAIRS / BLACKFRIARS.

C. 1720-40. L-TYPE 25. S.B.P. 2 MM. BASE/STEM FRAGMENT. PERHAPS EARLIER THAN NO. 8 AND POSSIBLY BY THE SAME MAKER.

FIG. 17.

1. (13.5.83.) QUEENHITHE.
 C. 1740-70. L. TYPE 25. S.B.D. 1.75 MM. CURVED, TALL BOWL, MEDIUM THICKNESS, WITH INTERNAL PLUNGER CROSS. CIRCULAR BASE. MAKER W/S. A NUMBER OF POSSIBLE MAKERS INCLUDING: WILLIAM STEVENS, 1729, ST. GEORGES IN THE EAST; WILLIAM STEWART, 1729, F.; WILLIAM STOKES, 1737.

2. (13.5.83.) QUEENHITHE.
 C. 1730-60. L. TYPE 25. S.B.D. 1.75. AN IRON-STAINED S/P BOWL, L.H.S. OF LIP BROKEN. A THICK, BROAD-IN-PROFILE BOWL. SMALL OVAL SPUR, LETTERED S/P.

3. (13.5.83.) TRIG LANE STAIRS / BLACKFRIARS.
 C. 1730-50. L. TYPE 25. S.B.D. 2.5 MM. BOWL FRAGMENT, L.H.S. BROKEN, SMOKE-STAINED AROUND INNER LIP. MAKER H/S. POSSIBLY HENRY SKINNER, 1703, F.

4. (13.5.83.) TRIG LANE STAIRS / BLACKFRIARS.
 C. 1730-50. L. TYPE 25. S.B.D. 2.5 MM. BOWL FRAGMENT, THIN STEM, SMALL ROUND SPUR. MAKER S/P. CLAY - WHITISH CREAM. IRON STAIN L.H.S.

5. (13.5.83.) TRIG LANE STAIRS / BLACKFRIARS.
 C. 1730-50. L. TYPE 25. S.B.D. 2.1 MM. BASE / STEM FRAGMENT, ROUND BASE. MAKER: I/S. A NUMBER OF POSSIBILITIES INCLUDING: JOHN SAYELL, 1722-63, WHITECROSS ST.

FIG. 17.

6. (13.5.83) TRIG LANE STAIRS / BLACKFRIARS.
 C. 1760-80. L. TYPE 25. S.B.D. 2 MM. THIN, CURVED BOWL, TAPERING TO CYLINDRICAL BASE. BACK/R.H.S. BROKEN. THIN STEM. MAKER; G/I. POSSIBLY GEORGE JOSCELYN, 1752.
7. (13.5.83) TRIG LANE STAIRS / BLACKFRIARS.
 C. 1730-60. L. TYPE 25. S.B.D. 2.1 MM. S/P BOWL FRAGMENT. CREAMY FABRIC. INTERNAL PLUNGER CROSS ON BASE. SLOPING, OVAL SPUR. STEM - MEDIUM THICKNESS; BOWL - SEEMINGLY THICK.
8. (13.5.83) TRIG LANE STAIRS / BLACKFRIARS.
 C. 1720-40. L. TYPE 25. S.B.D. 2.5 MM. LARGE, THICK, UPRIGHT BOWL, CURVING TO SQUARISH BASE. MAKER W/P?
9. (13.5.83) TRIG LANE STAIRS / BLACKFRIARS.
 C. 1720-40. L. TYPE 25. S.B.D. 3 MM. DISCOLOURED BOWL - TOP BROKEN. LARGE CYLINDRICAL BASE. MARKED; W/M - WITH CROWNS. PROBABLY WILLIAM MAMBY (2), 1719-63.
10. (29.4.83) QUEENHITHE.
 C. 1720-50. L. TYPE 25. S.B.D. 2.2 MM. BOWL FRAGMENT WITH INTERNAL BASE CROSS. CYLINDRICAL SPUR. LETTERED, WITH CROWNS, G/S. POSSIBLY GEORGE STRAY (STAW, STACE) (1), 1699-1725 OR (2) 1763. EXECUTION DUCK.

FIG. 17.

11. (26.4.83.) QUEENHITHE.

C. 1730-50. L. TYPE 25. S.B.D. 2.4 MM. CAPACIOUS, THICK, BOWL, TAPERING TO ROUND BASE. FABRIC SMOOTH, CREAMY GREY. MAKOR S/P. STEM THICK.

12. (26.4.83.) QUEENHITHE.

C. 1730-50. L. TYPE 25. S.B.D. 2.1 MM. PIPE SIMILAR TO NO. 11. VERY DISCOLOURED, BROWN AND RUST. ROUND VENT - BACK OF BOWL. POSSIBLE TRACE OF INTERNAL PLUNGER MARK COVERED BY DOTTLER FROM PIPE STEM BORE.

13. (26.4.83.) SOUTHWARTH BRIDGE/DOWGATE.

C. 1720-40. L. TYPE 25. S.B.D. 2.5 MM. IRON-STAINED, THICK PIPE, WELL-SMOKED, SHALLOW ROUND/DYAL BASE. MAKOR P/C. UNCITED. STEM - THICK.



FIG 18.

1. (25.5.83.) QUEENHITHE.

C. 1730-50. L. TYPE 25. S.B.D. 2.5 MM. BOWL FRAGMENT, SHOWING LARGE INTERNAL PLUNGER CROSS. OVAL BASE. MAKER: W/P. Cf. FIG. 2, NO. 10; FIG 4, NO'S 9 & 10; FIG. 8, NO. 5; FIG. 14, NO. 4.

2. (25.5.83.) TRIG LANE STAIRS / BLACKFRIARS.

C. 1740-60. L. TYPE 25. S.B.D. 2.3 MM. BACK PART OF WEATHERED BOWL, SMALLISH OVAL BASE, TRACE OF SEAM LINE. MAKER'S INITIALS: W/S. THE SAME CURIOUS DOUBLE 'S' MARK AS FIG. 5. NO. 9 AND PROBABLY BY SAME MAKER. A NUMBER OF POSSIBLE MAKERS.

3. (13.5.83.) SOUTHWARK BRIDGE / DOWGATE.

C. 1730-50. L. TYPE 25. S.B.D. 2.2 MM. SHORT, THICK BOWL, TOP FRONT / L.H.S. MISSING. CYLINDRICAL SPUR. MAKER: A/H. PROBABLY ABLE HORTON, 1717, SOUTHWARK OR ANTHONY HAYNES, 1722 F.

4. (16.11.82.) PAUL'S WHARF.

C. 1720+ S.B.D. 1.99 MM. STEM/BASE OF BOWL WITH POINTED SPUR AND EIGHT POINTED STAR IN RELIEF ON INTERNAL BASE. PIPE PROBABLY DATES FROM 1720-50, UNUSUAL FOR PIPES OF THIS PERIOD TO BE FOUND WITH SPUR IN LONDON. POSSIBLY IT ORIGINATES FROM CHESTER OF BROSELEY.

5. (6.10.82.)

C. 1720-50. L. TYPE 25. S.B.D. 2.28 MM. UNUSUALY SMALL AND UPRIGHT BOWL FOR ITS TYPE, SMOKE-STAINED AROUND LIP. SMALL, SLOPING, ROUND BASE. THICK STEM. BURNISHED, LIGHT MUSHROOM CLAY. VERY DIFFICULT TO DATE, BUT POSSIBLY BEFORE 1750 BECAUSE OF THICKNESS OF STEM.

6. (7.6.83.) QUEENHITHE

C. 1730-50. L. TYPE 25. S.B.D. 2.15 MM. THICK, WIDE-MOUTHED S/P BOWL, SMOKE-STAINED LIP, BUFF, SMOOTH CLAY. SLOPING BASE IN PROFILE. NP CHIPPED, L.H.S.

FIG. 18.

- 7. (7.6.83.) QUEENHITHE.
C. 1730-50. L. TYPE 25. S.B.D. 2.5 MM. THICK, WIDE-MOUTHED, FAIRLY SHORT BOWL. CYLINDRICAL BASE. LETTERED I/S? MANY POSSIBLE MAKERS.

- 8. (7.6.83.) QUEENHITHE.
C. 1740-60. L. TYPE 25. S.B.D. 2 MM. BASE/STEM FRAGMENT. SHINY, LIGHT BUFFY-MUSHROOM CLAY. FLAT, OVAL BASE. 'I' WITH PELLET, L.H.S.; 'P', R.H.S. A NUMBER OF POSSIBLE MAKERS INCLUDING: JOHN PINKARD (2) 1732 F.; JOHN PAYSON, 1745; JOHN POWNALL, 1748. APP. R. ST. MARGARET'S WESTMINSTER.

- 9. (7.6.83.) SOUTHWARK BRIDGE/DOWGATE.
C. 1730-50. L. TYPE 25. S.B.D. 2.4 MM. LARGE, WIDE BOWL, TAPERING TO CYLINDRICAL BASE. HEAVY IRON-STAINS BOTTOM HALF OF BOWL. RAISED DOT, R.H.S.

- 10. (7.6.83.) TRIG LANE STAIRS/BLACKFRIARS.
C. 1720-40. L. TYPE 25. S.B.D. 2 MM. DISCOLOURED BASE/STEM PIECE, INTERNAL BASE EXPOSED TO SHOW GRID-LIKE PLUNGER MARK IN RELIEF. LARGE CIRCULAR BASE WITH LARGE MOULDED LETTERS: H/P. THIS PIPE COULD BE ATTRIBUTED TO HUMPHREY PARBATT, 1729. ST. GEORGE IN EAST.

- 11. (23.6.83.) TRIG LANE STAIRS/PAUL'S WHARF.
C. 1740-60. L. TYPE 25. S.B.D. 2.36 MM. BASE/STEM FRAGMENT WITH INTERNAL PLUNGER CROSS. THIN STEM. SMALL OVAL BASE. LETTERED S/P.

- 12. (23.6.83.) QUEENHITHE.
C. 1720-40. L. TYPE 25. S.B.D. 2 MM. WELL-SMOKED, FAIRLY SMALL BOWL, THICK FRONT LIP, IRREGULAR BASE. DARK STAIN L.H.S. OF BOWL. MAKER: I/P. SEVERAL POSSIBLE MAKERS: JOHN PINKARD (1) 1703 (F); JOHN PINKARD (2) 1732 (F); OR PERHAPS JOHN PAYSON, 1745. BUT HE IS MORE LIKELY TO BE THE MAKER OF NO. 8.

FIG. 18.

13. (23.6.83.) QUEENHITHE.

C. 1730-60. L-TYPE 25. S.B.D. 2.3 MM. THICK, BROAD BOWL, FRONT BROKEN, SMALL OVAL BASE, MEDIUM STEM. MAKER D/C ? OR POSSIBLY G. DANIEL CRABB, 1723 APP. R. CLERKENWELL, COULD BE THE MAKER.

14. (23.6.83.) SOUTHWARK BRIDGE/DOWGATE.

C. 1720-40. L-TYPE 25. S.B.D. 2.3 MM. FAIRLY THICK, NARROW BOWL, FRONT LP CHIPPED. DISCOLOURED. SQUARISH BASE WITH TRACE OF MOULD LINE. SMALL MAKER'S LETTERS: M/G. POSSIBLY MOSES GEE, THOUGH OSWALD (1975) LISTS HIM AS WORKING 1681-96 F. O.A. VINTRY. S. MARTINS.

15. (16.9.85.) QUEENHITHE.

C. 1725-50. L-TYPE 25. S.B.D. 2.4 MM; MEDIUM TO THICK BOWL, FAIRLY NARROW; DUN, MOTTLED, POLISHED SURFACE; ROUND STEM-BREAK; SHALLOW, ROUND BASE; A/H MAKER. SEE NO. 3. ALSO Cf. FIG. 1, NO. 3; FIG. 19, NO. 4.



FIG. 19.

1. (15.7.83.) QUEENHITHE.
C. 1730-50. L. TYPE 25. S.B.D. 1.9 MM. WIDE-MOUTHED, THICKISH BOWL, CREAMY MUSHROOM FABRIC, BURNISHED, SMOKE STAINS IN CAVITY. OVALAR BASE. MAKER E/O UNCLASSIFIED BY OSWALD.
2. (15.7.83.) QUEENHITHE
C. 1730-50. L. TYPE 25. S.B.D. 2.1 MM. THICK, WIDE-MOUTHED S/P BOWL. IRON STAINED. THIN-MEDIUM STEM. SMALL, OVAL SPUR. SOLOMON PRICE (2) 1696-1722) O.A. (J). F. IS POSSIBLY THE MAKER IF HE WAS WORKING AFTER 1722. ALTHOUGH BECAUSE THESE PIPES ARE USUALLY SO THICK, IT IS POSSIBLE THEY WERE MADE C. 1720. A DIFFICULT PIPE TO DATE, AS THE SPUR AND STEM ARE SMALL AND THIN ENOUGH TO BE MADE IN THE 30'S TO 50'S.
3. (15.7.83.) QUEENHITHE.
C. 1720-40. L. TYPE 25. S.B.D. 2.1 MM. BROKEN BOWL, THICK, GREYISH FABRIC. CHIPPED, SHALLOW SPUR. MAKER R/C. POSSIBLY RICHARD CHILD, 1708. F. Cf. ALSO FIG. 3. NO'S 7 & 6; FIG. 6, NO. 12. FOR OTHER R/C PIPES.
4. (15.7.83.) QUEENHITHE.
C. 1720-50. L. TYPE 25. S.B.D. 2.2 MM. NARROW, UPRIGHT BOWL OF SMALL SIZE. OVALAR BASE. MAKER A/H. POSSIBLY ABLE HORTON, 1717, SOUTHWARK OR ANTHONY HAYNES, 1722, F.
5. (15.7.83.) QUEENHITHE.
C. 1720-50. L. TYPE 25. S.B.D. 1.98 MM. THICK BOWL OF CREAMY BUFF FABRIC, SMOKE STAINS ROUND LIP. ROUND BASE, SHALLOW AT FRONT. INTERNAL PLUNGER LINE. MAKER G/S. CROWNS ABOVE LETTERS. POSSIBLY MADE BY GEORGE STRAY (STAW, STACE) (1) 1717, OR GEORGE SIMPSON, 1718, F.

FIG. 19.

6. (15.7.83) QUEENHITHE.

C. 1720-50. L-TYPE 25. S.B.D. 1.65. WIDE, THINNISH BOWL OF WHITISH FABRIC. SHALLOW, OVULAR BASE WITH ROSETTE AND CRESCENT MOTIFS EACH SIDE. AN UNUSUAL COMBINATION OF SYMBOLS.

7. (15.7.83) TRIG LANE STAIRS / BLACKFRIARS.

C. 1720-40. L-TYPE 25. S.B.D. 2.6 MM. DISCOLOURED, UPRIGHT BOWL, VENT R.H.S. BASE, CHIPPED LIP AT BACK, SMALL OVULAR BASE, SHALLOW IN DEPTH. SMALL MAKER'S INITIALS: H/P OR POSSIBLY H/R. HENNERY PARKE, 1696 O.A. (J.); HUMPHREY PARBATT, 1729. ST. GEORGE IN EAST. J.F.C.

8. (15.7.83) TRIG LANE STAIRS / BLACKFRIARS.

C. 1730-60. L-TYPE 25. S.B.D. 2 MM. SMOOTH, SEMI-POLISHED, WIDE MOUTHED BOWL, MEDIUM STEM. CYLINDRICAL BASE. LARGE MAKER'S INITIALS W/P. POSSIBLY WILLIAM PEARCE, 1754, BRISTOL POLLS. CF. ALSO, FOR OTHER W/P PIPES: FIG. 2, NO. 10; FIG. 4, NO. 9; FIG. 8, NO. 5; FIG. 14, NO. 4; FIG. 15, NO. 12; FIG. 18, NO. 1. AND IN BATTERSEA (MISCELLANEOUS), 1720-80, FIG. 2, NO. 4. A LARGE AMOUNT OF THESE EXAMPLES HAVE PLUNGER CROSSES.

9. (26.7.83) QUEENHITHE.

C. 1730-50. L-TYPE 25. S.B.D. 2.2 MM. BOWL FRAGMENT, SOME IRON STAINS, WHITISH FABRIC. SMALL, SHALLOW, OVULAR BASE. LETTERED R/S. POSSIBLE MAKERS INCLUDE: RICHARD STEELE, 1704-45, F., SOUTHWARK, RICHARD SANDS, 1725. F. AND ROBERT SMITH, 1732, ST. GEORGE'S, WESTMINSTER.

10. (26.7.83) QUEENHITHE.

C. 1720-40. L-TYPE 25. S.B.D. 2.5 MM. BOWL FRAGMENT, THICK FABRIC, IRON STAIN BACK OF BOWL, SHALLOW BASE, LETTERED I/H. POSSIBLE MAKER: JOHN HOWELL, 1730, ST. ANDREWS HOLBORN, AMONG OTHERS.

FIG. 19.

11. (26.7.83.) QUEENHITHE.

C. 1730-50. L. TYPE 25. S.B.D. 2.9 MM. DISCOLOURED S/P BOWL FRAGMENT WITH BLACKENED CAVITY AND A CURIOUS, CRACKED YELLOW GLAZE.

12. (26.7.83.) QUEENHITHE.

C. 1750-70. L. TYPE 25. S.B.D. 2 MM. FRAGMENT OF SLIM BOWL, LONG, OVULAR BASE, LETTERED I/W. INNER BOWL WITHOUT A BASE, AND CURVING TO STEM BORE. POSSIBLY JOHN WOOD, 1763, WHITCROSS ST, OR JONAS WICKHAM, 1774-84, BRISTOL POLLS, WAPPING.

13. (26.7.83.) QUEENHITHE.

C. 1720-40. L. TYPE 25. S.B.D. 2.15 MM. BLACKENED BOWL FRAGMENT. CYLINDRICAL BASE, LETTERED S/P. INTERNAL BASE CROSS. POSSIBLY ATTRIBUTABLE TO SOLOMON PRICE (2), 1696-1722. O.A.(J).F.

14. (26.7.83.) TRIG LANE STAIRS / BLACKFRIARS

C. 1750-80. L. TYPE 25. S.B.D. 2.2 MM. SLENDER BOWL, WHITISH FABRIC, BACK/TOP BROKEN. OVULAR BASE LETTERED R/P. POSSIBLY ROBERT PATTISON, 1755, GOULD ST. GERMONOSEY, OR RICHARD PINKARD, 1761, OLD MONTAGUE ST., WHITECHAPEL. Cf. FIG. 16, NO. 1 (R/P WITH CROWNS)

FIG. 20.

1. (15.7.83.) TRIG LANE STAIRS / BLACKFRIARS.
 C. 1750-60. L. TYPE 26. S.B.D. 2 MM. BROKEN ARMORIAL, ALMOST IDENTICAL TO BAR 97, P. 125, NO. 32. VISIBLE ON THIS EXAMPLE IS THE WHITE HORSE OF HANOVER, BACK OF BOWL, A ROSE, L.H.S.; THE 'SPIRE' MOTIF ON THE FRONT AND THE RIBBON WITH THE MOTTO 'DIEU ET MON PROIT'. THE SPUR IS UNMARKED.

2. (26.7.83.) TRIG LANE STAIRS / BLACKFRIARS.
 C. 1730-40. L. TYPE 25. S.B.D. 2.5 MM. BOWL FRAGMENT. SMALLISH, SHALLOW BASE, LETTERED B/M. UNCITED BY OSWALD.

3. (9.8.83.) QUEENHITHE.
 C. 1750. L. TYPE. 25. S.B.D. 2.2 MM. BASE/STEM FRAGMENT, MUSHROOM L.H.S., OFF-WHITE, R.H.S. SHALLOW, ROUND BASE. MAKER B/T. THE LETTER 'T' HAS A PELLET BELLOW. BY BENJAMIN TURNER, 1749, WESTMINSTER, PROBABLY. CF. FIG. 3 NO 6.

4. (9.8.83.) QUEENHITHE.
 C. 1720-40. L. TYPE 25. S.B.D. 2.4 MM. VERY THICK, WIDE MOUTHED BOWL, ARMYISH FABRIC, SMOOTH AND SEMI-POLISHED. CHIP L.H.S. OF LIP. OVULAR BASE. MAKER Q/S. PROBABLY GEORGE STRAY (STAW, STACE) (1), 1699-1725.

5. (9.8.83.) QUEENHITHE.
 C. 1730-50. L. TYPE 25. S.B.D. 2.5 MM. WELL-SMOKED, BROWNY-GREY S/P BOWL, LIP CHIPPED FRONT. OVULAR BASE. 'S' PARTLY OBSCURED.

6. (9.8.83.) BROOKS WHARF.
 C. 1730-50. L. TYPE 25. S.B.D. 2.1 MM. BOWL/STEM FRAGMENT, ANGLED BASE, MAKER: S/P.

7. (3.1.83) QUEENHITHE
 C. 1720-50. L. TYPE 25. S.B.D. 2 MM. THICK, MUSHROOM COLOURED BOWL. THICK STEM. MAKER: R/S. CF. FIG. 19, NO 9; FIG. 2, NO'S. 6 & 9. RICHARD STEBLE 1704-45, SOUTHWARK, A POSSIBLE.

FIG. 20.

- 8. (15.8.83) QUEENHITHE.
C. 1730-50. L. TYPE 25. S.B.D. 2 MM. GREYISH S/P BOWL, MEDIUM THICK. LIP CHIPPED, FRONT. SMALL OVULAR SPUR.

- 9. (15.8.83.) QUEENHITHE
C. 1730-50 L. TYPE 25. S.B.D. 2.2 MM. S/P BOWL FRAGMENT, DAPPLED GREY. INTERNAL PLUNGER CROSS

- 10. (15.8.83) QUEENHITHE.
C. 1730-50 L. TYPE 25. S.B.D. 2.2 MM. BROKEN BOWL. SHALLOW, OVULAR SPUR WITH STYLISED CROWNS EACH SIDE.

- 11. (15.8.83) QUEENHITHE.
C. 1720-60. L. TYPE 25. S.B.D. 2.8 MM. TALL, SMOOTH, UPRIGHT BOWL, FRONT BROKEN. SMOKE STAINS IN UPPER CAVITY. OVULAR BASE WITH W/M AND CROWNS. ATTRIBUTABLE TO WILLIAM MANBY (2) 1719-63

- 12. (15.8.83) QUEENHITHE.
C. 1720-40. L. TYPE 25. S.B.D. 2.1 MM. FAIRLY SHORT, FORWARD CURVING BOWL, SMOOTH AND GREYISH. THICK STEM. OVULAR BASE. MAKER H/S. POSSIBLY HENRY SKINNER, F. 1703. Cf. FIG. 3, NO. 10; FIG. 5, NO. 4; FIG. 10, NO. 6.

- 13. (15.8.83.) QUEENHITHE.
C. 1730-50. L. TYPE 25. S.B.D. 1.9 MM. SMOKE STAINED CAVITY, FRONT BROKEN. IRREGULAR BASE, LETTERED I/B. POSSIBLY 1741, YORK POLLS, JOSEPH BURRILL, CROWN COURT, ST. GILES.



FIG. 21.

- 1. (15.8.83) QUEENHITHE/BROOK'S WHARF
C. 1720-40. S.B.D. 1.8 MM. SIMILAR MUSHROOM GREY COLOURED BOWL TO FIG. 12 NO. 11. THICK IN SECTION WITH SMALL SPUR.

- 2. (22.8.83.) QUEENHITHE/BROOK'S WHARF.
C. 1730-50. L. TYPE 25. S.B.D. 1.98 MM. BROKEN, WELL SMOKED BOWL. CYLINDRICAL SPUR, LETTER F/S WITH CROWNS. PROBABLY FRANCIS STRAY (STAGE, STAW) 1732, F. THE CROWNS HAVE A CURIOUS 'FEATHERED' EDGE TO THEM. Cf. FIG. G. NO. 10; FIG. 14, NO. 9, BOTH OF WHICH HAVE INTERNAL PLUNGER MARKS.

- 3. (22.8.83.) QUEENHITHE/BROOK'S WHARF
C. 1720-60 L. TYPE 25 S.B.D. 2 MM. TYPICAL W/M BOWL, BACK BROKEN, CLAY SEEMS BRITTLE, MUSHROOM IN COLOUR. CYLINDRICAL BASE. CROWNS ABOVE LETTERS. WILLIAM MANBY (2) 1719-63. GREEN DRAGON ALLEY.

- 4. (22.8.83) QUEENHITHE/BROOK'S WHARF.
C. 1720-50 L. TYPE 25. S.B.D. 2.1 MM. THICK, WIDE, GOOD QUALITY BOWL, POLISHED, SHALLOW, FLAT BASE, VERY CLEAN CUT LETTERS: T/R. PERHAPS A NEW MOULD. PROBABLE MAKER: THOMAS RAM, 1718, SOUTHWARK. (APP. R.)

- 5. (22.8.83) QUEENHITHE/BROOK'S WHARF.
C. 1720-30. L. TYPE 25. S.B.D. 2.1 MM. TALL, SMOOTH, THICK BOWL WITH CROWN AND HARP MOTIFS ON SIDES OF BASE. BLACKENED TOP LIP/CAVITY.

- 6. (12.8.83) TRIG LANE STAIRS/BLACKFRIARS.
C. 1720-50. L. TYPE 25. S.B.D. 2.1 MM. LARGE, GREY BOWL. LARGE, SLANTING BASE, LETTERED L/G. PROBABLY LAWRENCE GRAYSTON, 1737 APP. R. HOLBORN.

FIG. 21.

7. (15.8.83) TRIG LANE STAIRS / BLACKFRIARS.

C. 1720-40. L-TYPE 25. S.B.D. 2.1 MM. BOWL FRAGMENT, SMOOTH, BRITTLE CLAY, SEMI-POLISHED. SHALLOW, OVULAR BASE: L.H.S. 3 PIPES; R.H.S. SUN MOTIF.

8. (15.8.83) TRIG LANE STAIRS / BLACKFRIARS.

C. 1750-70. L-TYPE 25. S.B.D. 2.1 MM. STEM/BASE PIECE. THICK, OFF-WHITE CLAY. STAMP OF WILLIAM TAPPIN, 1763. BLACKFRIARS.

9. (15.8.83) TRIG LANE STAIRS / BLACKFRIARS.

C. 1760-70. L-TYPE 25. S.B.D. 1.7 MM. BROKEN, SLENDER BOWL, SLOPING, OVAL SPUR. THIN STEM. MAKER: I/H. PROBABLY JOHN HARVEY, 1739, BRISTOL POLLS.

10. (31.8.83) QUEENHITHE.

C. 1720-40. L-TYPE 25. S.B.D. 2.9 MM. DAPPLED, DISCOLOURED BOWL, SMOOTH CLAY. TALL AND NARROW. OVULAR BASE. MAKER: C/W. POSSIBLY CHARLES WILLSON, 1696, O.A.(J).

11. (15.8.83) PAUL'S WHARF.

C. 1750-70. L-TYPE 25. S.B.D. 1.75 MM. GREYISH BOWL FRAGMENT, POLISHED. THIN, ROUND STEM. NARROW, OVAL BASE, CHIPPED. W. TAPPIN'S STAMP BEARLY VISIBLE. THIS PIPE IS EVIDENCE THAT TAPPIN DID CHANGE HIS MOULDS TO THE SLIMMER MORE REFINED PIPES OF THE 60'S AND 70'S. HOWEVER, THE STAMPS REMAINS THE SAME!

12. (7.10.83) QUEENHITHE.

C. 1720-40. L-TYPE 25. S.B.D. 2.1 MM. THICK, WIDE W/P BOWL. WILLIAM PINKARD IS LISTED, 1696-1715 F. WHITECHAPEL TPM BY TRADE 1708-15. POSSIBLY HE WORKED ON AFTER THIS. PERHAPS THIS PIPE IS BY AN UNRECORDED MAKOR, BECAUSE THE STYLE IS TYPICAL OF 1720-50. AGAIN PROBABLY TOO EARLY FOR WILLIAM PEARCE, 1754, BRISTOL POLLS. FOR OTHER W/P EXAMPLES SEE FIG. 18, NO. 1; FIG. 15, NO. 12; FIG. 14, NO. 4; FIG. 8, NO. 5; FIG. 4, NO'S. 9 & 10; FIG. 2, NO. 10.



FIG. 21.

13. (7. 10. 83.) QUEENHITHE.

C. 1720-60. L. TYPE 25. S.B.D. 1.98 MM. A WILLIAM MANGY PIPE WITH W/M AND CROWNS ON SPUR. SPECKLED FABRIC. CHIP L.H.S. OF LIP. WORKING 1719-63.

14. (7. 10. 83.) QUEENHITHE.

C. 1720. L. TYPE 25 S.B.D. 2.1MM SHINY FABRIC. INTERNAL PLUNGER CROSS. SQUARE BASE. SMALL 'H'; LARGE 'S'. EITHER HENRY SKINNER, 1703. F. OR HUMPHREY SIMKINS, 1696-1711. F.(OB). W'MINSTER, BUT BEARING IN MIND THE INNER CROSS WHICH OCCURS ON BOWLS IN THE MAIN POST 1720, PERHAPS THE FIRST MAKER, GIVEN A LONG WORKING LIFE.

15. (9. 9. 83) QUEENHITHE.

C. 1720-50. L. TYPE 25. S.B.D. 2.2 MM. S/P BOWL, TOP BROKEN, CYLINDRICAL SPUR. TINY INITIALS, LETTERS THIS SMALL ARE NOT UNKNOWN ON PIPES EARLIER THAN THIS, SO IT IS NOT AN INDICATION OF AGE. Cf. THE LARGER S/P LETTERED BOWLS.



FIG. 22.

1. (24.10.83.)

C. 1725-50. L. TYPE 25. S.B.D. 2.25 MM. FUNNEL SHAPED S/P PIPE BOWL, INTERNAL CROSS IN RELIEF ON BASE. MOTTLED DISCOLOURATION. BOWL THICKNESS AT LIP 1-3 MM. SMALL, SHALLOW BASE. SOLOMON PRICE (2) 1696-1722 (O.A.(J). F.) LIKELY TO HAVE WORKED AFTER 1722, PERHAPS S/P (3) CARRIED ON WITH THE BUSINESS.

2. (24.10.83.) DOWGATE.

C. 1710-40. L. TYPE 25. S.B.D. 2.1 MM. TALL, UPRIGHT, SMOOTH BOWL, MEDIUM IN SECTION, SMALL A/S ON SPUR. PERHAPS ABRAHAM SHEPARD, 1721, TOOK ON AN APPRENTICE, OR ABRAHAM SANDS, 1725. F.

3. (24.10.83.) DOWGATE.

C. 1710-40. L. TYPE 25. S.B.D. 2.1 MM. SIMILAR TO ABOVE BUT WITH LARGER A/S. FOUND CLOSE TOGETHER.

4. (24.10.83.) PAUL'S WHARF.

C. 1750-80. L. TYPE 25. S.B.D. 2 MM. IRON STAINED BOWL FRAGMENT. FLEUR-DE-LYS ON SPUR.

5. (23.2.83.) TRIG LANE STAIRS/PUDDLEDOCK.

C. 1725-60. L. TYPE 25. S.B.D. 2 MM. TALL, WIDE-MOUTHED BOWL, SMOOTH FABRIC, IRREGULAR BASE. MAKER: H/S. H IS CUT OVER ANOTHER LETTER.

6. (23.2.83.) TRIG LANE STAIRS/PUDDLEDOCK.

C. 1740-60. L. TYPE 25. S.B.D. 2 MM. ROUND BASE, BUFF/CREAM FABRIC. W/W ON SPUR. PERHAPS WILLIAM WILDER 1717-63. F. WHITECROSS ST.

7. (23.2.83.) TRIG LANE STAIRS/PUDDLEDOCK.

C. 1740-60. L. TYPE 25. S.B.D. 1.9 MM. SIMILAR TO ABOVE. OVAL BASE. INTERNAL CROSS.

FIG. 22.

8. (17.10.83.) TRIG LANE STAIRS / PUDDLEDOCK.

C. 1750-70. TYPOLOGICAL DATE C. 1700-20. L-TYPE 25. S.B.D. 2 MM. TALL, THICK WILLIAM TAPPIN BOWL. GREEN STAINING. STAMP MARRED, PERHAPS BY A FINGER PRINT. IT SEEMS STRANGE THAT THESE PIPES ARE ATTRIBUTED TO W. TAPPIN, 1763, BLACKFRIARS WHEN THE MOULDS OBVIOUSLY RELATE TO THE 1720'S. WAS TAPPIN STILL USING THE ORIGINAL MOULDS FROM HIS EARLY CAREER? IT SEEMS IMPROBABLE AS SURELY THEY WOULD HAVE BEEN WORN BY THE 1760'S. THE MYSTERY REMAINS.

9. (24.10.83.) TRIG LANE STAIRS / PUDDLEDOCK.

C. 1720-60. L-TYPE 25. S.B.D. 2.2 MM. THICK, FAIRLY OVAL STEM. THICK BOWL SECTION AT STEM. 6- SPOKED INTERNAL PLUNGER CROSS. LETTERED T/?; PERHAPS A RETROGRADE 'S.'

10. (9.9.83.) QUEENHITHE.

C. 1720-40. L-TYPE 25. S.B.D. 2.1 MM. BOWL FRAGMENT, PROBABLY OF A TALL, UPRIGHT BOWL; ROUND, SHALLOW BASE. MAKER W/L. PERHAPS WILLIAM LONG, 1689-1720. TOOK AN APPRENTICE, 1720. 1692-98, QUEENHITHE. POLL TAX. ASSESS.

11. (13.10.83.) QUEENHITHE.

C. 1720-50. L-TYPE 25. S.B.D. 2 MM. BOWL FRAGMENT. SMALL BASE. MAKER E/S. POSSIBLY ENGRAVED OVER EARLIER LETTERS. PERHAPS LATE BOWLS OF EDWARD STEELE 1686-96 F. O.A. (J), OR SON? EDWARD SMITH 1696-99 O.A. (J) F., OR SON? OR EDWARD SHEEREMAN, 1696, O.A. (J).

12. (13.10.83.) QUEENHITHE.

C. 1720. L-TYPE 25. S.B.D. 2.8 MM. THICK STEM. BASE STAMP OF STAR OR SUN IN RELIEF. PROBABLY CROWNS AND FLOWERHEADS SIDES OF SPUR.



(1982/83)

FIG. 22.

13. C. 1730-60. A WELL-SMOKED, POLISHED DUTCH BOWL, WITH CROWNED SH MONOGRAM IN RELIEF ON SPUR. SEVERAL MAKERS USED OR RENTED THIS MARK; POSSIBLY A PRODUCT OF STEVEN DE JONG'S GOUDA FACTORY, 1734-46, WHO'S WIDOW CONTINUED WITH THE MARK UNTIL 1761, OR PIETER WITSIUS WHO WORKED WITH IT DURING THE SAME PERIOD. S.B.D. 2 MM. DOWGATE.

14. (20. 1. 84.) QUEENHITHE / DOWGATE

C. 1725-40. L. TYPE 25. S.B.D. 2.4 MM. LARGE, FUNNEL SHAPED BOWL, BUFF, AND IRON STAINING / GREY DAPPLES. THICK FABRIC. WIDE MOUTH. INTERNAL BASAL MARK IN RELIEF, MADE AT ANGLE TO STEM. SHALLOW, FLATTENED ROUND BASE. SHALLOW GROOVE RUNNING AT ANGLE TO STEM. MAKER S/P?

15. (20. 1. 84.) TRIGLANE STAIRS / PAUL'S WHARF.

C. 1725-45. L. TYPE 25. S.B.D. 2.03 MM. GREYISH, SHINY FABRIC. OVAL STEM. ROUND BASE. MOULD LINE REMAINING IN CENTRE. INTERNAL PLUNGER MARK, 6 INCISIONS. CRESCENTS ON SIDES OF BASE. Cf. FIG. 5, NO. 8. WHICH HAS NO INTERNAL MARKS BUT COULD BE FROM THE SAME MOULD. THIS WOULD INDICATE AN EARLIER DATE OF MANUFACTURE. WHY THESE INCISIONS WERE LATER MADE ON THE PLUNGER CAN ONLY AT PRESENT BE GUESSED AT.

16. (20. 1. 84.) TRIGLANE STAIRS / PAUL'S WHARF.

C. 1730-50. L. TYPE 25. S.B.D. 2 MM. LIGHT FAWN BOWL FRAGMENT. ROUNDISH SPUR. STEM CHIPPED L.H.S. MAKER R/B. POSSIBLY R. BARRETT, APP. R. 1719, APP. TO G. BAYLEY, £4, WORKING ST. ANDREWS, HOLBORN; RICHARD BRYANT, 1733-40; ROBERT BALDWIN, 1749, CHYMISTER ALLEY. ST. MARTINS WESTMINSTER. POLLS. THERE ARE INDICATIONS THAT UNDER THE R/B HE PREVIOUSLY MOULDED LETTERS. PERHAPS THE A/H THAT ONE R/B MAKER TOOK OVER (OR CAME INTO PARTNERSHIP WITH) AS INDICATED BY THE R/B BOWL STAMP ON SOME EXAMPLES. HOWEVER WITH THESE THE A/H MOULDINGS ARE INEVARIABLY LEFT ON. (SEE FIG. 1, NO. 7.).

FIG. 23.

1. (20.1.84.) SOUTHWARK BRIDGE/DOWGATE.

C. 1720-40. L. TYPE 25. S.B.D. 2 MM. TALL, FAIRLY NARROW, OFF-WHITE BOWL. SMOKE-STAINED CAVITY. CIRCULAR STAIN, FRONT/L.H.S. SHALLOW, OVAR BASE. MAKER I/R. THICK, ROUND STEM. PERHAPS JOHN REYNOLDS (2) 1718-30. F. BAPT. CHILD P. REGS. ST. GEORGE IN THE EAST, OR JAMES ROOME, 1730 F.

2. (20.1.84.) SOUTHWARK BRIDGE/DOWGATE.

C. 1725-50. L. TYPE 25. S.B.D. 2.58 MM. IRON STAINED, SHORTISH, BROKEN BOWL. CYLINDRICAL BASE. MAKER E/R. THICK STEM. LIKELY EDWARD RANDALL, 1719, APP. R. BOWES HIS APP. £5. NO OTHER SO FAR RECORDED FROM THIS BANK.

3. (20.1.84.) SOUTHWARK BRIDGE/DOWGATE.

C. 1730-50. L. TYPE 25. S.B.D. 2.15 MM. FORWARD SLOPING S/P BOWL. WHITISH CLAY. THICK, BROKEN BOWL. ROUNDISH, DOWNWARD SLOPING SPUR, WITH 'THUMB?' INDENTATIONS.

4. (3.2.84.) QUEENHITHE.

C. 1720-45. L. TYPE 25. S.B.D. 2.3 MM. THICK, OPEN MOUTHED, GREYISH BOWL, DISCOLOURED R.H.S. SMOKED CAVITY. SHALLOW, SQUARISH BASE. CHIPPED. LIP CHIPPED R.H.S./BACK. LETTERED ON SIDES OF BASE: T/S-C. PROBABLY THE MAKER T/S TAKING OVER THE MOULD OF T/C. LIKELY THOMAS CLELAND 1711. T. SIMPKINS HIS APP. BY TURNOVER. F. HOWEVER OSWALD ALSO LISTS ONLY ONE T. SIMPKINS, 1711-18. APP. R. WESTMINSTER, BUT AS APPRENTICED TO J. HIGGINS £6. F.

5. (3.2.84.) QUEENHITHE.

C. 1720-45. L. TYPE 25. S.B.D. 2.25 MM. THICK, GREYISH BOWL, WITH DISCOLOURATIONS. CLEAN CAVITY. OVAL SPUR. MAKER I/W. ONE POSSIBLE JEREMIAH WETHERBY, 1727 CARRPREGATE. BAPT. S. AHLESBURY P. REGS. MANY OTHERS. I/W PIPES FOUND AT BRENT KILN, SEE BAR 97, P. 45.



FIG. 23.

1. (20.1.84.) SOUTHWARK BRIDGE/DOWGATE.

C. 1720-40. L. TYPE 25. S.B.D. 2 MM. TALL, FAIRLY NARROW, OFF-WHITE BOWL. SMOKE-STAINED CAVITY. CIRCULAR STAIN, FRONT/L.H.S. SHALLOW, OVAR BASE. MAKER I/R. THICK, ROUND STEM. PERHAPS JOHN REYNOLDS (2) 1718-30. F. BAPT. CHILD P. REGS. ST. GEORGE IN THE EAST, OR JAMES ROOME, 1730 F.

2. (20.1.84.) SOUTHWARK BRIDGE/DOWGATE.

C. 1725-50. L. TYPE 25. S.B.D. 2.58 MM. IRON STAINED, SHORTISH, BROKEN BOWL. CYLINDRICAL BASE. MAKER E/R. THICK STEM. LIKELY EDWARD RANDALL, 1719, APP. R. R. BOWES HIS APP. £5. NO OTHER SO FAR RECORDED FROM THIS BANK.

3. (20.1.84.) SOUTHWARK BRIDGE/DOWGATE.

C. 1730-50. L. TYPE 25. S.B.D. 2.15 MM. FORWARD SLOPING S/P BOWL. WHITISH CLAY. THICK, BROKEN BOWL. ROUNDISH, DOWNWARD SLOPING SPUR, WITH 'THUMB?' INDENTATIONS.

4. (3.2.84.) QUEENHITHE.

C. 1720-45. L. TYPE 25. S.B.D. 2.3 MM. THICK, OPEN MOUTHED, GREYISH BOWL, DISCOLOURED R.H.S. SMOKED CAVITY. SHALLOW, SQUARISH BASE. CHIPPED. LIP CHIPPED R.H.S./BACK. LETTERED ON SIDES OF BASE: T/S-C. PROBABLY THE MAKER T/S TAKING OVER THE MOULD OF T/C. LIKELY THOMAS CLELAND 1714. T. SIMPKINS HIS APP. BY TURNOVER. F. HOWEVER OSWALD ALSO LISTS ONLY ONE T. SIMPKINS, 1711-18. APP. R. WESTMINSTER, BUT AS APPRENTICED TO J. HIGGENS £6. F.

5. (3.2.84.) QUEENHITHE.

C. 1720-45. L. TYPE 25. S.B.D. 2.25 MM. THICK, GREYISH BOWL, WITH DISCOLOURATIONS. CLEAN CAVITY. OVAL SPUR. MAKER I/W. ONE POSSIBLE JEREMIAH WETHERBY, 1727 CRIPPLEGATE. BAPT. S. AHLESBURY P. REGS. MANY OTHERS. I/W PIPES FOUND AT BRENT KILN, SEE BAR 97, P. 45.

FIG. 23.

6. (3.2.84) QUEENHITHE.

C. 1725-50. L. TYPE 25. S.B.D. 2.05 MM. WIDE-MOUTHED BOWL, RIM-THICK TO THIN. DIRTY TAN COLOUR. MEDIUM STEM. SLOPING BASE IN PROFILE. MAKER S/P. SOLOMON PRICE (2) WAS A FATHER IN 1722. THESE S/P BOWLS, PROBABLY THE COMMONEST INITIALS OCCURRING, WERE LIKELY MADE BY S. PRICE (2), CONSIDERING A LONG WORKING LIFE, OR PERHAPS HIS SON. IN GENERAL, THE PIPES SEEM TO DATE PRE - 1760 AND AFTER THE FASHION OF TALL, NARROWER-MOUTHED BOWLS OF THE FIRST DECADES OF THE EIGHTEENTH CENTURY. SOME BEAR PLUNGER CROSSES, WHICH AS OSWALD NOTES, BAR 97, P. 74, OCCURS ON PIPES POST 1720. HOWEVER HIS TIME LIMIT OF C. 1720-60 CAN BE LENGTHENED WELL INTO THE 19th, THOUGH HERE OCCURRING WITH LESS FREQUENCY. AN 'ACORN' BOWL FROM WATERLOO, LIKELY POST 1850 HAS A RADIATING BASAL STAR, CAUSED BY INCISING THE SIDES/TIP OF PLUNGER.

7. (3.2.84) QUEENHITHE.

C. 1725-50. L. TYPE 25. OFFWHITE FABRIC. THICK BOWL SECTION. CYLINDRICAL BASE. MAKER: W/P. Cf FIG. 21 NO. 12, AND FOR DISCUSSION ON MAKER. S.B.D. 2 MM.

8. (3.2.84) PAUL'S WHARF.

C. 1750-80. L. TYPE 25. S.B.D. 2 MM. P.O.W.F. THIN IN SECTION. NO FRONT DECORATION. GREYISH FABRIC. R/B ON SPUR. LIKELY IDENTICAL TO NO. T. P. 105, BAR 97. ALSO FROM PAUL'S WHARF. PERHAPS ROBERT BALDWIN, WESTMINSTER 1749; RICHARD BOUCHER, 1766, SUN INS. £100; RICHARD BRYANT, FL. 1735-70.

9. (17.2.84) QUEENHITHE

C. 1730-70. L. TYPE 25. S.B.D. 2 MM. TALL, MEDIUM THICK BOWL, MOTTLED BLACK L.H.S., IRON STAINS R.H.S. LONG NARROW SPUR. ROYAL CROWNS MOULD-IMPARTED ON SIDES.

10. (5.5.84) QUEENHITHE.

C. 1720-40. L. TYPE 25. S.B.D. 2.2 MM. THICK, ROUND STEM. SHALLOW BASE. DISCOLOURED SURFACE. R AND LARGER S ON SIDES OF BASE. PERHAPS RICHARD STEBBIE, 1704-45. F. SOUTHWARK. 1718, T. RAM HIS APP. £5. 1745, J. PAYSON HIS APP. £5 APP. R. BUT THERE ARE OTHER POSSIBLES. Cf FIG. 20, NO. 7.

FIG. 23.

11. (13.6.84.) QUEENHITHE.
C. 1750-60. L-TYPE 25. S.B.D. 2 MM. BASAL FRAGMENT; MEDIUM THICK FABRIC;
PERHAPS BLURRED INTERNAL PLUNGER CROSS. NARROW, CHIPPED BASE. MAKER APPARENTLY
W/W. PERHAPS WILLIAM WILDER, 1717-63. F. WHITECROSS ST. D. Cf. FIG. 1, NO. 9
FOR COMPLETE BOWL WITH W/W LETTERS.

12. (13.6.84.) QUEENHITHE.
C. 1750-70. L-TYPE 25. S.B.D. 2 MM. SMOKED BOWL FRAGMENT, SMOOTH, NARROW
BASE. MAKER: W/T. PERHAPS WILLIAM TAPPEN OF PUDDLE DOCK HILL. 1763 SUN LIFE
ASSURANCE POLICY. BLACKFRIARS. ALTHOUGH THIS EXAMPLE IS NOT CHARACTERISTIC OF
HIS TYPICAL PRODUCTS WHICH WERE GENERALLY LARGE EARLY TYPES, STAMPED ON
THE BASE.

13. (13.6.84.) QUEENHITHE.
C. 1720-50. L-TYPE 25. S.B.D. 2.45 MM. THICK BOWL FRAGMENT WITH DOWNWARD-
SLOPING INTERNAL BASE; OVAL, SHALLOW BASE; IRONS STAINS FRONT OF BOWL; ROUND
STEM-BREAK WITH CENTRAL BORE. MAKER: T/C. MANY POSSIBILITIES.

14. (5.5.84.) PAUL'S WHARF.
C. 1760-70. L-TYPE 25. S.B.D. 2 MM. NARROW BOWL, THICK AT BREAK; STEM SNAPPED
OBLIQUELY; SMALL CYLINDRICAL SPUR. MAKER: W/W. SEE NO 11.

15. (10.8.84.) QUEENHITHE.
C. 1740-60. L-TYPE 25. S.B.D. 2 MM. SHINY, SMOOTH FABRIC; CHIPPED, OVAL BASE;
INITIALS: H/D WITH WELL-CUT CROWNS AND CHARACTERISTIC 'FEATHERED' EDGES. MAKER UNCERTAIN,
PERHAPS A LATE HENRY DOUGLAS PIPE, 1708 F.

FIG. 24.

1. (17.2.84.)

C. 1760-70. L-TYPE 25. S.B.D. 2MM. DISCOLOURED ARMORIAL (LANOVARIAN) LEAVES OR 'FEATHERS' ON FRONT SCAM; OVAL SPUR; BLURRED SHIELD; MOTTO, RIBBON AND SUPPORTERS. ROUND STEM-BREAK; CENTRAL BORE. MAKER R/A. UNKNOWN.

2. (JUNE/JULY 1984.) SOUTHWARK BRIDGE AREA.

C. 1720-40. L-TYPE 25. S.B.D. 2.50 MM. THICK, ROUND STEM, CENTRAL BORE. IRREGULARLY ROUND BASE, OBLIQUE, WITH 'SCRAPE' LINES. MAKER B/S. PERHAPS BENJAMIN STEPHENSON, 1713. F.

3. (10.8.84.) QUEENHITHS.

C. 1730-50. L-TYPE 25. S.B.D. 1.5 MM. OFF-WHITE FABRIC WITH IRON TINGE; THICKISH BOWL; MAKER I/B. MANY POSSIBLES. THE NARROW STEM BORE DIAMETER MAY INDICATE A BOWL OF MID-CENTURY MANUFACTURE.

4. (10.8.84.) PAUL'S WHARF.

C. 1720-30. L-TYPE 25. S.B.D. 2.1 MM. NARROW, MEDIUM-THICK BOWL; MOTTLED DECOLOURATION; SHALLOW, ALMOND SHAPED BASE; ROUND STEM BREAK, CENTRAL BORE; MAKER: I/E. A NUMBER OF POSSIBLE MAKERS INCLUDING JOHN ELDRIDGE, 1719, F.

5. (28.9.84.)

C. 1725-50. L-TYPE 25. S.B.D. 2.075 MM. SHORT, SMOKED, THICK BOWL; THICK STEM; OVAL SPUR; H/S MAKER. HENRY SKINNER, F. 1703, OR PERHAPS HIS SON.

6. (28.9.84.)

C. 1750-60. L-TYPE 25. S.B.D. 2 MM. OFF-WHITE, ROUGH FABRIC; WATER ROLLED; ALGAE IN CAVITY BASE; CHIPPED BASE; MAKER W/W. WILLIAM WILDER 1717-63. F. WHITEDROSS ST. D.

7. (28.9.84.)

C. 1725-50. L-TYPE 25. S.B.D. 2.075 MM. SEE NO. 5 ABOVE. INTERNAL PLUNGER MARK.

FIG. 24.

8. (28.9.84.) PAUL'S WHARF.

C. 1760-80+. THIN FABRIC; STYISH ENGRAVING - LION AND CHAINED UNICORN; PART OF MOTTO ON RIBBON SHOWING, 'DIE..... - PROBABLY HANNOVARIAN ARMS; LEAF SPRAYS EITHER SIDE OF FRONT SEAM; MAKER UNKNOWN.

9. (8.10.84.) PAUL'S WHARF.

C. 1760-80 L-TYPE 26. S.B.D. 1.98 MM. SMOKE, THIN FABRIC; IRON STAINS; FORWARD POINTED SPUR WITH W/B ON SIDES; SEAM LINE ON FRONT; HANNOVARIAN ARMS; FEATHER SHOWING ON FRONT SEAM; L.H.S. BROKEN. PERHAPS WILLIAM BROWN (1) 1752. ST. GILES IN THE FIELDS. £200 SU. ASS. LE CHAMINANT RECORDS THIS BOWL FIG. 4. NO. 9, AND DESCRIBES THE MOTTO AS FORESHORTENED 'DIEU ET MON DR.' HOWEVER ON THE ABOVE THE MOTTO EXTENDS TO 'DRO'.

10. (24.2.85.)

C. 1720-50. L-TYPE 25. S.B.D. 2.2 MM. IRON STAINED FABRIC; CEMENT LIKE MATTER ENCRUSTED IN CAVITY; MAKER: N/H. N RETROGRADE. POSSIBLY NATHANIELL HOWELL, 1696 O.A.(J), OR NATHANIELL HEBBLEWHITE, 1763. GRAYS INN LANE. D.

11. (24.2.85.)

C. 1750-80. L-TYPE 25. S.B.D. 2 MM. SMOOTH, OVAL BASE. MAKER N/A. UNKNOWN.

12. (21.3.85.)

C. 1720-40. L-TYPE 25. S.B.D. 2.1 MM. THICK BOWL, CHIPPED R.H.S./FRONT; SMOOTH, LIGHT GREYISH WHITE SURFACE; OVAL STEM-BREAK; SMOOTH, ROUND BASE; FLOWER HEAD L.H.S, WITH EIGHT PETALS; H + FLOWERHEAD? R.H.S.

13. (20.5.85.) PAUL'S WHARF.

C. 1760-80 L-TYPE 25. S.B.D. 2 MM. SHINY, IRON STAINED FRAGMENT; MEDIUM THICKNESS; ROUND STEM BREAK - CENTRAL HOLE; CYLINDRICAL SPUR; FLEUR-DE-LYS (OR TOBACCO PLANTS?) ON SPUR SIDES. CF. FIG. 3, NO. 11, LIKELY BY SAME MAKER.

FIG. 24.

14. (1985)

c. 1750-70. L-TYPE 25. S.B.D. 2 MM. MEDIUM FABRIC; SLENDER FORM; OVAL BASE; SMOOTH SURFACE; SPECKLED DISCOLOURATION ON FRONT. MAKER T/W. THOMAS WOOLLARD, 1757. SOUTHWARK. £200. SU. ASS.; THOMAS WARD (? 2) 1763 (DB.) SHOREDITCH. ARCHDEAC. LOND. WILLS.; THOMAS WOOD, 1763-
c. 1800. WHITCROSS ST. D. PIPE. cf. FIG. 16, NO. 4.

15. (1985)

c. 1730-60. L-TYPE 25. S.B.D. 2.2 MM. THICK, SMOKED BOWL; RATHER SQUAT; GREYISH FAWN COLOUR; OVAL BASE, SLIGHT MOULD LINE SHOWING; I/H MAKER. A NUMBER OF POSSIBLES. cf. FIG. 4, NO. 11; FIG. 5, NO. 10; FIG. 13, NO. 10; FIG. 19, NO. 10.

